

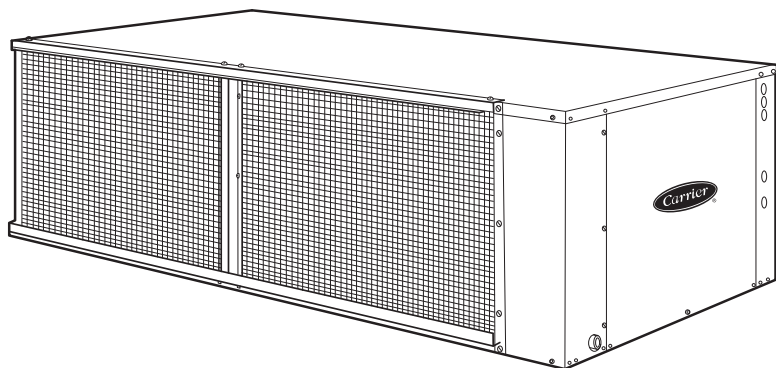

## Product Data

# AQUAZONE™ 50HQP072-120 Large Capacity Horizontal Water Source Heat Pumps with PURON® Refrigerant (R-410A)

6 to 10 Nominal Tons



Single-package horizontally mounted water source heat pumps with electronic controls.

- Puron® refrigerant (R-410A)
- Performance certified to AHRI/ISO/ASHRAE 13256-1
- Wide application use with an entering water operating temperature range of 20 F to 110 F
- Dual refrigerant circuits for 2-stage operation
- High-efficiency scroll compressors
- Thermostatic expansion valve (TXV) provides efficient and reliable refrigerant flow
- High-static capability available
- Available mute package for quiet operation
- Available low temperature insulation to prevent condensation
- Easy service access
- Flexible and reliable controls accommodate all systems (LON and PremierLink™ controls)

## Features/Benefits

**Carrier's Aquazone™ large capacity units offer low cost, energy efficient solutions for all challenging water source heat pump applications.**

### Operating efficiency

Carrier's Aquazone horizontal water source heat pumps (WSHPs) are designed for quality and high performance over a lifetime of operation. Aquazone units offer cooling EERs (Energy Efficiency Ratio) to 20.0 and heating COPs (Coefficient of Performance) to 5.0. Efficiencies stated are in accordance with standard conditions under ISO (International Organization for Standardization) Standard 13256-1 and provide among the highest ratings in the industry, exceeding ASHRAE (American Society of Heating, Refrigerant and Air Conditioning Engineers) 90.1 Energy Standards.



# Features/Benefits (cont)



## High quality construction and testing

All units are manufactured to meet extensive quality control protocol from start to finish through an automated control system, which provides continuous monitoring of each unit and performs quality control checks as equipment progresses through the production process. Standard construction features of the Aquazone™ units include:

**Cabinet** — Standard unit fabrication consists of heavy gauge galvanized sheet metal cabinet construction that provides maximum strength. Cabinet interior surfaces are lined with 1/2 in. thick, dual density, 1<sup>3</sup>/<sub>4</sub> lb per cubic ft acoustic, fiberglass type insulation. Sheet metal surfaces are treated for maximum corrosion protection to ensure resilience for long term vitality. The condensate pan is coated with baked-on enamel finish and insulated.

**Compressor** — Aquazone large-capacity units include dual high-capacity scroll compressors. Compressor isolating springs are specially selected for each compressor size. The external isolation springs are mounted on an isolated railing system to minimize vibrations to the unit structure.

**Blower and motor assembly** — Belt-driven centrifugal blowers are provided with all units to satisfy many air distribution applications. Optional motor speeds and sizes are available to provide high-static capability. Aquazone blower motors are designed to operate at lower temperatures to help improve the reliability of the WSHP.

**Refrigeration/water circuit** — Units have a sealed refrigerant circuit including a scroll compressor. Refrigerant circuits are provided with a standard thermostatic expansion valve (TXV) for higher accuracy and performance. Also standard are a reversing valve (4-way

valve), water-to-refrigerant coaxial (tube-in-tube) coil, and enhanced aluminum fin/rifled copper tube air-to-refrigerant heat exchanger coil.

## Environmentally sound

Carrier's Puron® refrigerant (R-410A) enables you to make an environmentally responsible decision. Puron refrigerant (R-410A) is an HFC refrigerant that does not contain chlorine that is damaging to the stratospheric ozone layer. Puron refrigerant (R-410A) is unaffected by the Montreal Protocol. Puron refrigerant (R-410A) is a safe, efficient and environmentally sound refrigerant for the future.

**AHRI/ISO** — Carrier's Aquazone units have AHRI (Air Conditioning, Heating and Refrigeration Institute)/ISO, NRTL (Nationally Recognized Testing Lab), or ETL labels and are factory tested under normal operating conditions at nominal water flow rates. Quality assurance is provided via testing report cards shipped with each unit to indicate specific unit performance under cooling and heating modes of operation.

## Quiet operation

Fan motor insulation and compressor springs are provided for sound isolation, cabinets are fully insulated to reduce noise transmission, low speed blowers are utilized for quiet operation through reduced outlet air velocities, and air-to-refrigerant coils are designed for lower airflow coil face velocities.

## Design flexibility

Airflow configuration for Aquazone horizontal units is available as left return and right discharge. Extended water temperature range between 20 F and 110 F offers maximum design flexibility for all applications. Water flow rates as low as 1.5 gpm per ton assist

with selection from a various range of circulating pumps. Factory-installed options are offered to meet specific design requirements.

## Safe, reliable operation

Standard safety features for the refrigerant circuit include high-pressure switch and low-pressure sensor to detect loss of refrigerant. A low air temperature sensor safeguards against freezing. Equipment safety features include water loop temperature monitoring, voltage protection, water coil freeze protection, and standard electronic condensate overflow shutdown. All Aquazone safety features are tested at the factory to assure proper operation of all components and safety switches.

All components are carefully designed and selected for endurance, durability, and carefree day-to-day operation.

The Aquazone unit is shipped to provide internal and external equipment protection. Shipping supports are placed under the blower housing and compressor feet. In addition, units are mounted on oversized pallets with lag bolts for sturdiness and maximum protection during transit.

## Ease of installation

The Aquazone unit is packaged for simple low cost handling, with minimal time required for installation. All units are pre-wired and factory charged with refrigerant. Water connections and condensate drains are anchored securely to the unit cabinet. High and low voltage knockouts are provided on all units.

## Simple maintenance and serviceability

The Aquazone™ WSHP units are constructed to provide ease of maintenance. Units allow access to

# Table of contents

Features/Benefits . . . . .	1-3
Model Number Nomenclature . . . . .	4
AHRI/ISO Capacity Ratings . . . . .	5
Physical Data . . . . .	6
Options and Accessories . . . . .	7-9
Dimensions . . . . .	10
Selection Procedure . . . . .	11,12
Performance Data . . . . .	13-20
Electrical Data . . . . .	21
Typical Piping and Wiring . . . . .	22
Typical Control Wiring Schematics . . . . .	23-25
Application Data . . . . .	26-29
Guide Specifications . . . . .	30-33



compressor section from 3 sides. Additional panels are provided to access the blower and control box sections.

The blower housing assembly can be serviced without disconnecting ductwork from the dedicated blower access panel. Blower units are provided with permanently lubricated bearings for worry-free performance.

Electrical disconnection of the blower motor and control box is easily accomplished from quick disconnects on each component.

Easy removal of the control box from the unit provides access to all refrigeration components.

The refrigeration circuit is easily tested and serviced through the use of high and low pressure ports integral to the refrigeration circuit.

### Maximum control flexibility

Aquazone water source heat pumps provide reliable control operation using a standard microprocessor board with flexible alternatives for many direct digital control (DDC) applications including the Carrier Comfort Network® (CCN) and open protocol systems.

Carrier's Aquazone standard unit solid-state control system, the Complete C, provides control of the unit compressor, reversing valve, fan, safety features, and troubleshooting fault indication features. The Complete C control system is one of the most user friendly, low cost, and advanced control boards found in the WSHP industry. Many features are field selectable to provide the ultimate in field installation flexibility. The overall features of this standard control system include:

**75-va transformer** assists in accommodating accessory loads.

**Anti-short cycle timer** provides a minimum off time to prevent the unit from short cycling. The 5-minute timer energizes when the compressor is deenergized, resulting in a 5-minute delay before the unit can be restarted.

**Random start relay** ensures a random delay in energizing each different WSHP unit. This option minimizes peak electrical demand during start-up from different operating modes or after building power outages.

**High and low pressure refrigerant protection** safeguards against unreliable unit operation and prevents refrigerant from leaking.

**Condensate overflow sensor**, mounted to the drain pan, recognizes thirty continuous seconds of condensate pan overflow as a fault. When

condensate pan liquid reaches an unacceptable level, unit is automatically deactivated and placed in a lockout condition.

**High and low voltage protection** safe guards against excessive or low voltage conditions.

**Automatic intelligent reset** automatically restarts unit 5 minutes after shutdown if the fault has cleared. Should a fault occur 3 times sequentially, lockout will occur.

**Accessory output** (24-v) is provided to cycle a motorized water valve or damper actuator with compressor in applications such as variable speed pumping arrangements.

**Performance Monitor (PM)** feature monitors water temperatures to warn when the heat pump is operating inefficiently or beyond typical operating range. Field selectable switch initiates a warning code on the unit display.

**Water coil freeze protection (selectable for water or anti-freeze)** field selectable switch for water and water/glycol solution systems initiates a fault when temperatures exceed the selected limit for 30 continuous seconds.

**Air coil freeze protection (check filter operation)** field selectable switch for assessing excessive filter pressure drop initiates a fault when temperatures exceed the selected limit for 30 continuous seconds.

**Alarm relay setting** is a selectable 24-v or pilot duty dry contact for providing activation of a remote alarm.

**Electric heat option** output provided on the controller for operating two stages of emergency electric heat.

**Service test mode with diagnostic LED (Light-emitting diode)** allows service personnel to check the operation of the WSHP and control system efficiently. Upon entering Test mode, time delays are sped up, and the Status LED will flash a code to indicate the last fault experienced for easy diagnosis. Based on the fault code flashed by the status LED, system diagnostics are assisted through the use of Carrier provided troubleshooting tables for easy reference to typical problems.

**LED visual output** indicates high pressure, low pressure, low voltage, high voltage, air/water freeze protection, condensate overflow, and control status on an LED panel.

**Open protocol for diverse control (LON controller)** option is ideal when building automation requires interoperability across diverse control

platforms. This LONMark\* compliant offering can operate as standalone or as a part of Local Operating Network (LON) via the LonWorks\* FTT-10 Free Topology communication network. Factory completed, pre-engineered applications specific to Aquazone water source heat pumps and digital wall sensors communicating over Sensor Link (S-Link) communication protocol completes a system of networked control.

### Carrier's PremierLink™ controller adds reliability, efficiency, and simplification

The PremierLink direct digital controller can be ordered as a factory-installed option. Designed and manufactured exclusively by Carrier, the controller can be used to actively monitor and control all modes of operation as well as monitor the following diagnostics and features: unit number, zone temperature, zone set point, zone humidity set point, discharge-air temperatures, fan status, stages of heating, stages of cooling, outdoor-air temperature, leaving-air temperature, leaving water temperature, alarm status, and alarm lockout condition.

This controller has a 38.4K baud communications capability and is compatible with *ComfortLink™* controls, CCN and *ComfortVIEW™* software. The scrolling marquee and Navigator™ display are optional tools that can be used for programming and monitoring the unit for optimal performance. The addition of an accessory CO<sub>2</sub> sensor in the conditioned space provides ASHRAE 62-99 compliance and demand controlled ventilation (DCV). A DCV control strategy is especially beneficial for a water source heat pump system to minimize the energy utilized to condition ventilation air. The DCV approach enhances the energy efficient performance of the Aquazone™ units.

The PremierLink peer-to-peer, Internet ready communicating control is designed specifically for constant volume (CV) and variable volume and variable temperature (VVT®) applications. This comprehensive controls system allows water source heat pumps to be linked together to create a fully functional HVAC (heating, ventilation, and air conditioning) automation system.

\* Registered trademark of Echelon Corporation.

# Model number nomenclature



50HQP 096 K C C 5 - 1 1 -

**50HQP** – Horizontal Large Capacity Water Source Heat Pump with Puron® Refrigerant (R-410A)

**Size – Nominal Tons**

- 072 – 6
- 096 – 8
- 120 – 10

**Airflow Configuration**

	Return	Discharge	Drive/Motor
<b>J</b>	– Right	Left	Standard/Standard
<b>K</b>	– Right	Back	Standard/Standard
<b>N</b>	– Left	Right	Standard/Standard
<b>P</b>	– Left	Back	Standard/Standard
<b>Q</b>	– Right	Left	Low Rpm/Standard
<b>T</b>	– Right	Back	Low Rpm/Standard
<b>U</b>	– Left	Right	Low Rpm/Standard
<b>V</b>	– Left	Back	Low Rpm/Standard
<b>W</b>	– Right	Left	High Rpm/Standard
<b>X</b>	– Right	Back	High Rpm/Standard
<b>Z</b>	– Left	Right	High Rpm/Standard
<b>1</b>	– Left	Back	High Rpm/Standard
<b>2</b>	– Right	Left	Standard/Large
<b>3</b>	– Right	Back	Standard/Large
<b>4</b>	– Left	Right	Standard/Large
<b>5</b>	– Left	Back	Standard/Large
<b>6</b>	– Right	Left	High Rpm/Large
<b>7</b>	– Right	Back	High Rpm/Large
<b>8</b>	– Left	Right	High Rpm/Large
<b>9</b>	– Left	Back	High Rpm/Large

**Water Circuit Options**

- – None

**Operating Range and Insulation**

- 1 – Commercial Standard Range
- 2 – Commercial Standard Range with Mute
- 3 – Commercial Extended Range
- 4 – Commercial Extended Range with Mute

**Packaging**

- 1 – Domestic (Single Pack)

**Revision Code**

- – Current Revision

**V-Ph-Hz**

- 1 – 575-3-60
- 5 – 208/230-3-60
- 6 – 460-3-60

**Heat Exchanger Options**

- A** – Copper Water Coil with E-Coated Air Coil
- C** – Copper Water Coil with Non-Coated Air Coil
- J** – Cupronickel Water Coil with E-Coated Air Coil
- N** – Cupronickel Water Coil with Non-Coated Air Coil

**Controls**

- C** – Complete C Microprocessor Control
- D** – Deluxe D Microprocessor Control
- L** – Complete C with LON\*
- M** – Deluxe D with LON\*
- P** – Complete C with PremierLink™ Communicating Control
- W** – Complete C Microprocessor Control with WSHP OPEN
- Y** – Deluxe D Microprocessor Control with WSHP OPEN

\*LON — LonWorks interface system.

**NOTES:**

1. Standard cabinet is powder-painted.
2. 208/230 volt unit is wired for 208 volts, but can be field converted to 230 volts.
3. 1-in. return filter included.
4. 75-VA standard transformer included.



# AHRI/ISO capacity ratings



## 50HQP072-120 UNITS

UNIT	GPM	CFM	WATER LOOP HEAT PUMP				GROUND WATER HEAT PUMP				GROUND LOOP HEAT PUMP			
			Cooling 86 F		Heating 68 F		Cooling 59 F		Heating 50 F		Cooling 77 F		Heating 32 F	
			Total Capacity (Btuh)	EER (Btuh/W)	Total Capacity (Btuh)	COP	Total Capacity (Btuh)	EER (Btuh/W)	Total Capacity (Btuh)	COP	Total Capacity (Btuh)	EER (Btuh/W)	Total Capacity (Btuh)	COP
50HQP072	20.0	2400	69,000	13.3	92,500	5.0	78,500	19.7	75,500	4.4	71,000	14.6	58,000	3.5
50HQP096	24.0	3200	95,600	13.7	123,000	5.0	104,500	20.0	101,000	4.4	98,000	15.2	77,000	3.6
50HQP120	30.0	4000	119,000	13.3	160,000	4.6	134,000	19.3	132,500	4.0	122,500	14.5	103,000	3.3

### LEGEND

**COP** — Coefficient of Performance  
**db** — Dry Bulb  
**EER** — Energy Efficiency Ratio  
**wb** — Wet Bulb

### NOTES:

- Cooling capacities based upon 80.6 F db, 66.2 F wb entering air temperature.
- Heating capacities based upon 68 F db, 59 F wb entering air temperature.
- All ratings based upon operation at lower voltage of dual voltage rated models.
- All 50HQP072 ratings are at 2400 cfm (1133 l/s) with 20 gpm (1.26 l/s). Sheave setting for AHRI is 2.5 turns open.
- All 50HQP096 ratings are at 3200 cfm (1510 l/s) with 24 gpm (1.51 l/s). Sheave setting for AHRI is 3.0 turns open.
- All 50HQP120 ratings are at 4000 cfm (1888 l/s) with 30 gpm (1.89 l/s). Sheave setting for AHRI is 3.0 turns open.



# Physical data



## 50HQ072-120 UNITS

UNIT 50HQP	072	096	120
<b>NOMINAL CAPACITY (tons)</b> Compressor(s)*	6	8 Scroll	10
<b>NOMINAL AIRFLOW (cfm)</b> Range (cfm)	2400 1800-3000	3200 2400-4000	4000 3000-4500
<b>WEIGHT (lb)</b> Operating Weight Shipping Weight	586 626	644 684	698 738
<b>AIR COIL</b> Total Face Area (sq ft) Tube Size (in.) Fin Spacing (FPI) Number of Rows	Aluminum Fins, Copper Tubes		
	7.5 $\frac{3}{8}$ 14 3	8.9 $\frac{3}{8}$ 14 3	8.9 $\frac{3}{8}$ 14 3
<b>REFRIGERANT CHARGE (R-410A) (oz/ckt)</b>	60	76	80
<b>NO. OF CIRCUITS</b>	2	2	2
<b>HIGH-VOLTAGE BUSHING (in.)</b>	1 $\frac{3}{4}$		
<b>BLOWER</b> Qty...Wheel Size (D x W) (in.) Range (rpm) Standard (hp...kW) Large (hp...kW)	1...12 x 12  1...0.75 2...1.49	1...12 x 12 760-1014 2...1.49 3...2.24	1...12 x 12  3...2.24 5...3.73
<b>REFRIGERANT-TO-WATER HEAT EXCHANGER</b> Connection (FPT) (in. ...TPI) Volume (gal.) Maximum Water Working Pressure (psig)	Steel-Copper or Steel-Cupronickel Tube-in-Tube		
	1.62 500	1 $\frac{1}{4}$ ...1 $\frac{1}{2}$ 1.81 500	1 $\frac{1}{2}$ ...1 $\frac{1}{2}$ 2.40 500
<b>CONDENSATE DRAIN CONNECTION — FTP (in. ...TPI)</b>	$\frac{3}{4}$ ...1 $\frac{1}{4}$		
<b>FILTER</b> Qty...Size (Height x Width) (in.)	1-in. Throwaway† 4...16 x 20		

### LEGEND

FPI — Fins per Inch  
TPI — Threads per inch

\*All units have grommet and spring compressor mountings, and 1/2-in. and 1 $\frac{3}{4}$ -in. electrical knockouts.  
†Two-inch filters are available as field-installed accessory.

# Options and accessories



DESCRIPTION	FACTORY-INSTALLED OPTION	FIELD-INSTALLED ACCESSORY
Cupronickel Heat Exchangers	X	
Sound Attenuation Package (Mute Package)	X	
Extended Range	X	
High-Static Blower Drive Options	X	
Deluxe D Control System	X	
WSHP Open Multiple Protocol Controller	X	
PremierLink™ Controller	X	
LONMARK Compliant Controller	X	
Aquazone™ Thermostats		X
Aquazone System Control Panel (50RLP)		X
Filter Rack (2 in.)		X
Fire-Rated Hoses		X
Ball Valves		X
Y Strainers		X
Solenoid Valves		X
Hose Kit Assemblies		X
Remote Sensors		X
PremierLink Accessories		X

## Factory-installed options

**Cupronickel heat exchangers** are available for higher corrosion protection for applications such as open tower, geothermal, etc. Consult the water quality guidelines for proper application and selection of this option.

**Sound attenuation package (mute package)** is available for applications that require especially low noise levels. With this option, a double application of sound attenuating material is applied, access panels are double dampened with 1/2-in. thick density fiberglass insulation, and a unique application of special dampening material is applied to the curved portion of the blower. The mute package in combination with standard unit noise reduction features (i.e., as mentioned previously) provides sound levels and noise reduction to the highest degree.

**Extended range** units provide an insulated water circuit for the coaxial coil and refrigerant circuit to prevent condensation, and therefore potential dripping problems, in applications where the entering water temperature is beyond the normal operating range (less than 60 F).

**High-static blower drive options** provide maximum flexibility for the most challenging applications. Three static range motors are available in low, standard, and high rpm configurations. An optional large motor arrangement is available for high-static designs.

**Deluxe D control system** provides the same functions as the Complete C control system while incorporating additional flexibility and functions to include:

Thermostat input capabilities accommodate emergency shutdown mode and night setback with override (NSB) potential. Night setback from low temperature thermostat with 2-hour override is initiated by a momentary signal from the thermostat.

Compressor relay staging is used with dual stage units (units with 2 compressors and 2 Deluxe D controls) or in master/slave applications.

Boilerless electric heat control system allows automatic changeover to electric heat at low loop water temperature.

Intelligent reversing valve operation minimizes reversing valve operation for extended life and quiet operation.

Thermostat type select (Y, O or Y, W) provides ability to work and select heat pump or heat/cool thermostats (Y, W).

Reversing valve signal select (O or B) provides selection for heat pump O/B thermostats.

Multiple units on one thermostat/wall sensor provide communication for up to three heat pumps on one thermostat.

Boilerless changeover temperature provides selection of boilerless changeover temperature set point.

Accessory relays allow configuration for multiple applications including fan and compressor cycling, digital night setback (NSB), mechanical night setback, water valve operation, and outside air damper operation.

**WSHP Open multiple protocol controller** is a proactive controller capable of communicating BACnet, Modbus, N2, and LON (with separate card) protocols. The controller is designed to allow users the access and ability to change and configure multiple settings and features including indoor air quality (IAQ), waterside economizer controls, etc.

**PremierLink™ controller** is compatible with the Carrier Comfort Network® (CCN) and other building automation systems (BAS). This control is designed to allow users the access and ability to change factory-defined settings, thus expanding the function of the standard unit.

**LONMARK compliant controller** contains the factory-loaded Aquazone water source heat pump application for an interoperable control solution.

## Field-installed accessories

**Carrier's line of Aquazone thermostats** are both attractive and multi-functional, accommodating stand-alone water source heat pump installations.

Programmable 7-day thermostat offers 2-stage heat, 2-stage cool, auto changeover, 7-day programmable with copy command, 4 settings per day, fully electronic, 24 vac, backlit LCD, keypad lockout, no batteries required, 5-minute compressor protection, NEVERLOST™ memory, 3 security levels, and temperature display in degrees F or C.

Programmable 7-day light-activated thermostat offers the same features as the 7-day programmable thermostat and

## Options and accessories (cont)



includes occupied comfort settings with lights on, unoccupied energy savings with lights off.

**Programmable 7-day flush-mount thermostat** offers the same features as the 7-day programmable thermostat and includes locking coverplate with tamper proof screws, flush to wall mount, holiday/vacation programming, set point limiting, dual point with adjustable deadband, O or B terminal, and optional wall or duct-mounted remote sensor.

**Programmable 5-day thermostat** offers 2-stage heat, 2-stage cool, auto changeover, 5-minute built-in compressor protection, locking cover included, temperature display in degrees F or C, keypad lockout, backlit display, 5-1-1 programming, O or B terminal, dual set point with adjustable deadband, configurable display, self-prompting program, and 4 settings per day.

**Non-programmable thermostat** offers 2 heat stages, 2 cool stages, auto changeover, 5-minute built in compressor protection, locking cover included, temperature display in degrees F or C, keypad lockout, large display, back-lit display, O or B terminal, dual set point with adjustable deadband, and backplate with terminals.

**Aquazone™ system control panel (50RLP)** includes a pre-programmed, easy to use, Carrier Comfort Controller set up for a WSHP system.

- Coordinates, monitors, and controls all WSHP units and ancillary equipment including cooling towers, boilers, and system pumps.
- 50RLP model nomenclature is used to customize the panel to control all WSHP system requirements.
- Panel can be ordered with 2, 4, 6, or 8 stages of system heat rejection.
- Panel can be ordered with 2, 4, 6, or 8 stages of system heat addition.
- Panel can be ordered with unique WSHP zone operation capabilities for stand-alone systems (i.e., non-communicating) to control 10 or 18 zones of WSHP unit.
- Panel can be ordered to control variable frequency cooling tower fan operation.
- System pumping operation can be configured for start/stop, lead/lag, or variable frequency pump operation.
- Direct digital control (DDC) compatible using the Carrier Comfort Network® (CCN) and WSHP units using PremierLink™ CCN controllers.

**Filter rack (2 in.)** is available in place of the standard 1-in. return air filter to enhance the filtration system of the water source heat pump. The 2-in. filter rack does not include filters.

**Fire-rated hoses** are 2 ft long and have a fixed MPT on one end and a swivel with an adapter on the other end. Hose kits are provided with both a supply and return hose and can be either stainless steel or galvanized. Five sizes are available (1/2, 3/4, 1, 1 1/4, 1 1/2 in.).

**Ball valves (brass body)** are used for shutoff and balancing water flow and are available with memory, memory stop, and pressure temperature ports. Valves con-

sist of UL-listed brass body, ball and stem type with Teflon\* seats and seals. Five sizes are available (1/2, 3/4, 1, 1 1/4, 1 1/2 in.).

**Y strainers (bronze body)** are “Y” type strainers with a brass cap. With a maximum operating pressure rating of 450 psig, the strainer screen is made of stainless steel. Strainers are available with blow down valves. Five sizes are available (1/2, 3/4, 1, 1 1/4, 1 1/2 in.).

**Solenoid valves (brass body)** offer 3.5 watt coil, 24 volt, 50/60 Hz, 740 amps inrush, and .312 amp holding. Valves operate slowly for quiet system application. Five sizes are available (1/2, 3/4, 1, 1 1/4, 1 1/2 in.).

**Hose kit assemblies** provide all the necessary components to hook up a water-side system. Supply hose includes a ported ball valve with pressure temperature (P/T) plug ports, flexible stainless steel hose with swivel and nipple. Return hose includes a ball valve, preset automatic balancing valve (gpm) with two P/T ports, flexible stainless steel hose with a swivel and nipple, balancing valve, and low-pressure drop water control valve.

**Remote sensors** are available for Aquazone flush mount thermostats. Available sensors are for wall (wired and wireless) or duct mounted applications.

**PremierLink™ accessories** are available for providing a fully integrated WSHP DDC system. Accessories include supply air temperature sensors (with override and/or set-point adjustment), communicating room sensors, CO<sub>2</sub> sensors (for use in demand control ventilation), and linkage thermostats (to control multiple units from one thermostat).

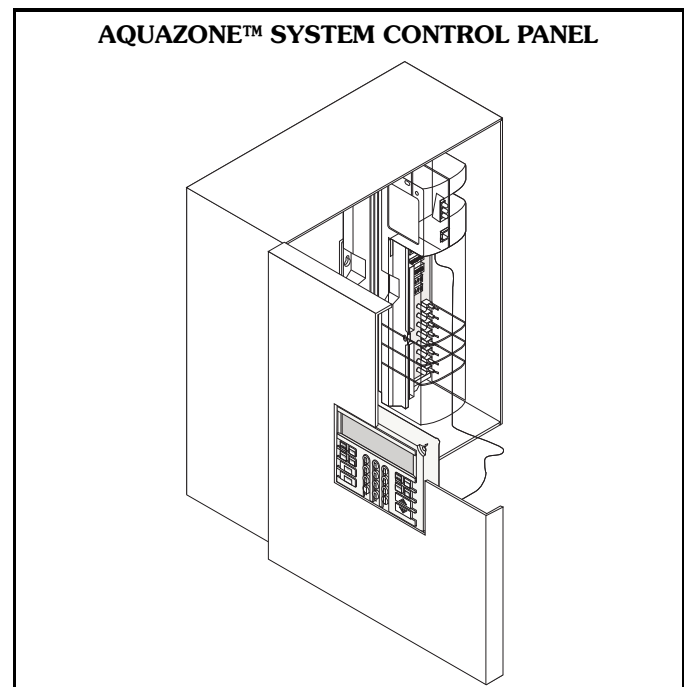

\*Teflon is a trademark of E. I. du Pont de Nemours and Company.

### CARRIER AQUAZONE THERMOSTATS

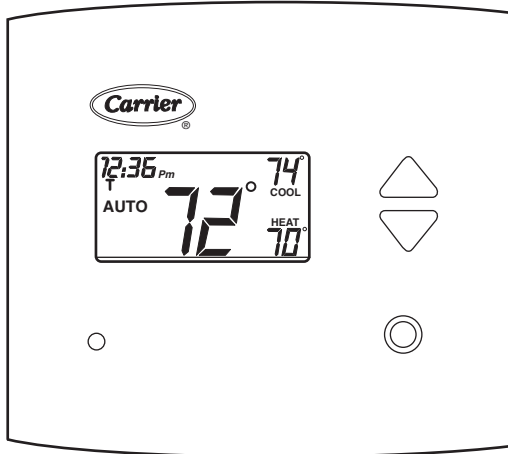

**7-DAY PROGRAMMABLE/LIGHT-ACTIVATED PROGRAMMABLE**

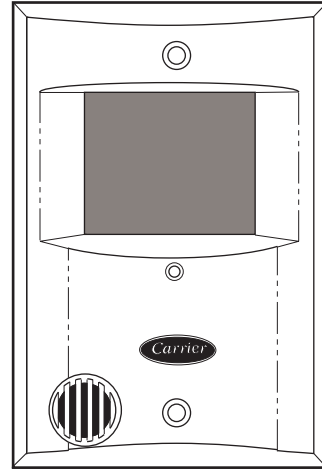

**7-DAY PROGRAMMABLE FLUSH MOUNT**

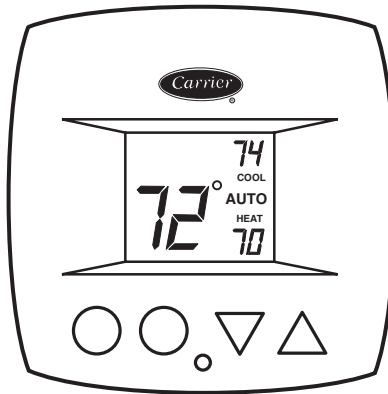

**5-DAY PROGRAMMABLE/NON-PROGRAMMABLE**

### PREMIERLINK™ COMMUNICATING CONTROL

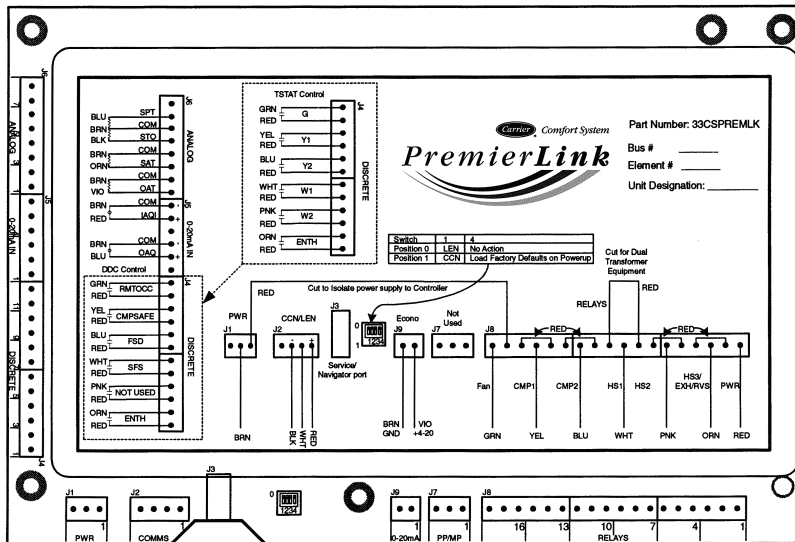

# Dimensions



## 50HQP072-120

LEFT RETURN STRAIGHT (RIGHT) DISCHARGE

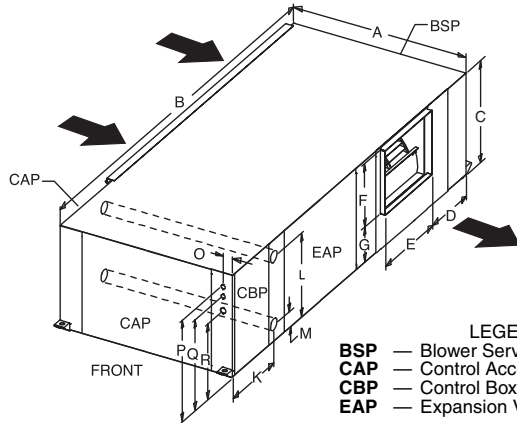

RIGHT RETURN STRAIGHT (LEFT) DISCHARGE

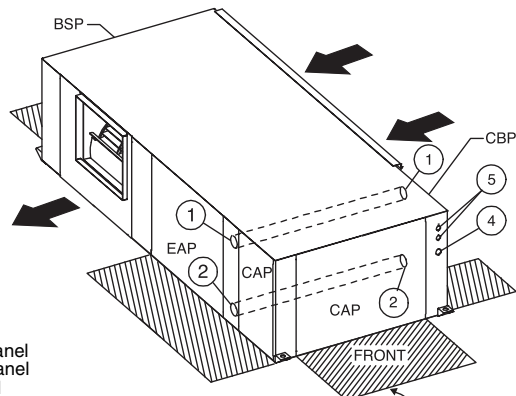

**LEGEND**  
**BSP** — Blower Service Panel  
**CAP** — Control Access Panel  
**CBP** — Control Box Panel  
**EAP** — Expansion Valve Access Panel

**NOTES:**

1. All dimensions in inches, unless indicated.
2. Access is required for all removable panels and installer should take care to comply with all building codes and allow adequate clearance.
3. Water inlet and outlet connections are available on either side of the unit. Plugs are shipped loose in a plastic bag tied to the water leg in front of the unit. Installer must plug unused connection.
4. Condensate drain connection is on end opposite of compressor.
5. Electrical access is available on either side of the front of the unit.
6. Electrical box is on right side but can be field-converted to left.

SERVICE ACCESS  
 3' (91 cm.) TYPICAL  
 ALL CONFIGURATIONS

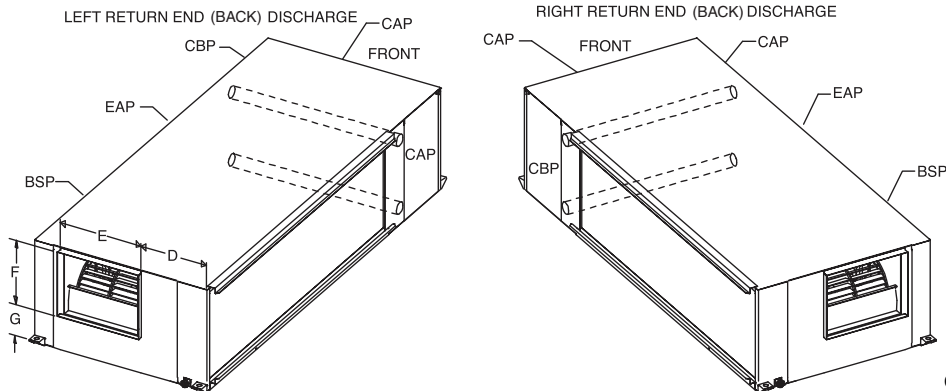
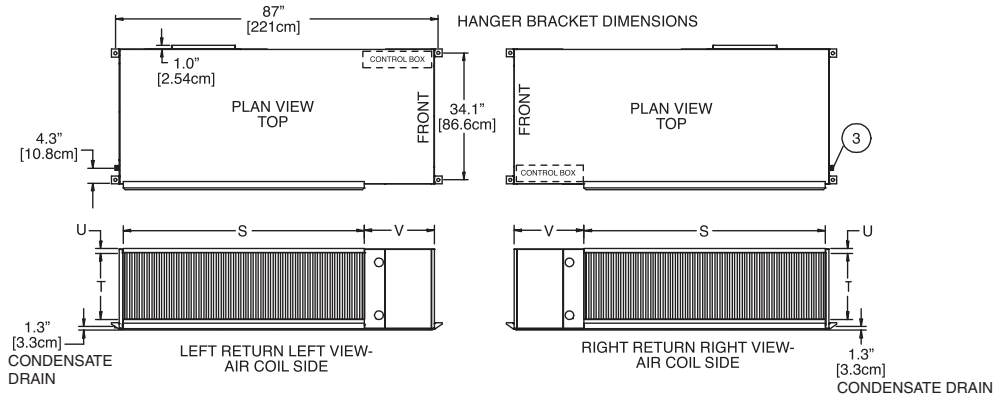

**CONNECTIONS**

- ① Water Outlet 1<sup>1</sup>/<sub>4</sub>" FPT (072,096)  
1<sup>1</sup>/<sub>2</sub>" FPT (120)
- ② Water Inlet 1<sup>1</sup>/<sub>4</sub>" FPT (072,096)  
1<sup>1</sup>/<sub>2</sub>" FPT (120)
- ③ Condensate Drain 3/4" FPT
- ④ High Voltage Access 1<sup>1</sup>/<sub>8</sub>" K.O.
- ⑤ Low Voltage Access 7/8" K.O.

UNIT 50HQP	OVERALL CABINET (in.)			DISCHARGE CONNECTIONS (in.) (Duct Flange ± 0.10 in.)				WATER CONNECTIONS (in.)			ELECTRICAL KNOCKOUTS (in.)				RETURN AIR CONNECTIONS (in.) (Using Return Air Opening)			
	A Depth	B Width	C Height	D	E Supply Depth	F Supply Height	G	K	L	M	O	P	Q	R	S Return Depth	T Return Height	U	V
072-120	36.3	84.9	21.6	14.0	17.0	13.5	7.8	15.0	8.3	4.0	2.0	18.8	16.8	13.8	65.0	18.0	1.0	18.9

# Selection procedure



## I Determine the actual cooling and heating loads at the desired dry bulb and wet bulb conditions.

Assume cooling load at desired dry bulb 80 F and wet bulb 65 F conditions are as follows:

Given:

Total Cooling (TC) . . . . . 65,500 Btuh  
 Sensible Cooling (SC) . . . . . 54,700 Btuh  
 Entering-Air Temperature db . . . . . 80 F  
 Entering-Air Temperature wb . . . . . 65 F

## II Determine the following design parameters.

Entering water temperature, water flow rate (gpm), airflow (cfm), water flow pressure drop and design wet and dry bulb temperatures. Airflow cfm should be between 300 and 450 cfm per ton. Unit water pressure drop should be kept as close as possible to each other to make water balancing easier. Enter the appropriate Performance Data tables and find the proper indicated water flow and water temperature.

For example:

Entering Water Temp (Cooling) . . . . . 90 F  
 Entering Water Temp (Heating) . . . . . 60 F  
 Water Flow . . . . . 15.0 GPM  
 Airflow Cfm . . . . . 2100 Cfm (350 Cfm/Ton)

## III Select a unit based on total cooling and total sensible cooling conditions. Unit selected should be closest to but not larger than the actual cooling load.

Enter tables at the design water flow and water temperature. Read the total and sensible cooling capacities.

NOTE: Interpolation is permissible, extrapolation is not.

Example equipment selection for cooling:

Enter the 50HQP072 Performance Table at design water flow and water temperature. Read Total Cooling, Sensible Cooling and Heat of Rejection capacities:

Total Cooling . . . . . 67,500 Btuh  
 Sensible Cooling . . . . . 52,300 Btuh  
 Heat of Rejection . . . . . 87,900 Btuh  
 Airflow Cfm . . . . . 2400 Cfm

NOTE: It is normal for water source heat pumps to be selected on cooling capacity only since the heating output is usually greater than the cooling capacity.

## IV Determine the correction factors associated with the variable factors of dry bulb and wet bulb using the Corrections Factor tables found in this book.

Using the following formulas to determine the correction factors of dry bulb and wet bulb:

a) Corrected Total Cooling = tabulated total cooling x wet bulb correction x airflow correction.

b) Corrected Sensible Cooling = tabulated sensible cooling x wet/dry bulb correction x airflow correction.

## V Determine entering air and airflow correction using the Corrections Factor tables found in this book.

The nominal airflow for the 50HQP072 is 2400 cfm. The design parameter is 2100 cfm.

2100/2400 = 88% of nominal airflow. Use the 88% row in the Airflow Correction table.

The nominal EAT (wb) is 67 F. The design parameter is 65 F. Use the 65 F correction factor row from the Entering Air Correction Factors table. Use design temperature 80 F (db) column for sensible cooling correction.

Using the following formulas to determine the correction factors of entering air and airflow correction:

	Table	Ent Air	Airflow	Corrected
Corrected Total Cooling	=	67,500	x 0.977 x 0.976	= 64,365
Corrected Sensible Cooling	=	52,300	x 1.089 x 0.933	= 53,139
Corrected Heat of Rejection	=	87,900	x 0.998 x 0.976	= 85,619

Compare the corrected capacities to the load requirements established in Step I. If the capacities are within 10% of the load requirements, the equipment is acceptable. It is better to undersize than oversize as undersizing improves humidity control, reduces sound levels and extends the life of the equipment.

## VI Determine the correction factor associated with antifreeze in system loop.

If heating EWT is 50 F or below, antifreeze may need to be used. Calculate leaving water temperature per performance data selection notes (operation is shaded areas). If antifreeze is required, use Anti-Freeze Correction table for correcting total and sensible capacities.

If the EWT for heating is 40 F, then the system requires antifreeze. If a solution of 15% propylene glycol is required, then:

Corrected Total Cooling = 64,365 x 0.986

Corrected Total Cooling = 63,464

Corrected Sensible Cooling = 53,139 x 0.986

Corrected Sensible Cooling = 52,395

## VII Water temperature rise calculation and assessment.

Calculate the water temperature rise and assess the selection using the following calculation:

$$\text{Actual Temperature Rise} = \frac{\text{Correction of Heat of Rejection}}{\text{GPM} \times 500}$$

# Selection procedure (cont)



For example, using the Corrected Heat of Rejection from the last step:

$$\text{Actual Temperature Rise} = \frac{85,619}{15.0 \times 500} = 11.4 \text{ F}$$

If the units selected are not within 10% of the load calculations, review what effect changing the GPM, water temperature and/or airflow will have on the corrected capacities. If the desired capacity cannot be achieved, select the next larger or smaller unit and repeat Steps I through VI.

## VIII AHRI/ISO/ASHRAE 13256-1 Conversion

Performance standard AHRI/ISO/ASHRAE 13256-1 became effective on January 1, 2000 and replaced the existing AHRI Standards 320 Water-Loop Heat Pumps (WLHP), 325 Ground-Water Heat Pumps (GWHP), and 330 Ground-Loop Heat Pumps (GLHP).

The AHRI/ISO Standard incorporates a consistent rating methodology for including fan and pump energy for calculating cooling capacity, heating capacity, and energy efficiency ratios (EER). This simplifies the use of rating data for heat pump performance modeling in seasonal energy analysis calculations, and allows for direct rating comparisons across applications.

### a) ISO Capacity and Efficiency Equations

The following equations are used to calculate and correct cooling capacity, heating capacity, and respective EER:

$$\text{ISO Cooling Capacity} = (\text{Cooling Capacity in Btuh}) + (\text{Fan Power Correction in Watts} \times 3.412)$$

$$\text{ISO Cooling EER} = (\text{ISO Cooling Capacity in Btuh}/3.412)/(\text{Power Input in watts} - \text{fan power correction in watts} + \text{pump power correction in watts}) = \text{Watts/Watts}$$

$$\text{ISO Heating Capacity} = (\text{Heating Capacity in Btuh}) - (\text{Fan Power Correction in Watts} \times 3.412)$$

$$\text{ISO Heating COP} = (\text{ISO Heating Capacity in Btuh}/3.412)/(\text{Power Input in watts} - \text{fan power correction in watts} + \text{pump power correction in watts}) = \text{Watts/Watts}$$

### b) Identify the design conditions corrected for air and water conditions.

$$\text{Airflow Cfm} = 2400 \text{ Cfm}$$

$$\text{Water Flow (based upon 11.4 F rise in temp)} = 15.0 \text{ GPM}$$

$$\text{External Static Pressure} = 0.5 \text{ in. wg}$$

$$\text{Water Pressure Drop} = 4.3 \text{ ft of head}$$

$$\text{Cooling Power Input} = 5,960 \text{ watts}$$

$$\text{Cooling Capacity} = 64,365 \text{ Btuh}$$

$$\text{Heating Power Input} = 5,500 \text{ watts}$$

$$\text{Heating Capacity} = 86,000 \text{ Btuh}$$

### c) Perform Fan Power Correction Adjustment

Use the following formula to calculate Fan Power Correction:

$$\begin{aligned} \text{Fan Power Correction} &= (\text{Cfm} \times 0.472) \times (\text{External Static Pressure} \times 249)/300 = \text{Watts} \\ &= (2400 \times 0.472) \times (0.5 \times 249)/300 \\ &= 470 \text{ Watts} \end{aligned}$$

### d) Perform Pump Power Correction Adjustment

Use the following formula to calculate Pump Power Correction:

$$\begin{aligned} \text{Pump Power Correction} &= (\text{GPM} \times 0.0631) \times (\text{Pressure Drop} \times 2,990)/300 = \text{Watts} \\ &= (15.0 \times 0.0631) \times (4.3 \times 2,990)/300 \\ &= 41 \text{ Watts} \end{aligned}$$

### e) Perform Cooling Capacity Calculation

Use the following formula to calculate cooling capacity:

$$\begin{aligned} \text{ISO Cooling Capacity} &= (\text{Cooling Capacity}) + (\text{Fan Power Correction} \times 3.412) \\ &= 64,365 + (470 \times 3.412) \\ &= 65,969 \text{ Btuh} \end{aligned}$$

### f) Perform Cooling EER Calculation

$$\begin{aligned} \text{ISO EER} &= (\text{ISO Cooling Capacity}/3.412)/(\text{Cooling Power Input} - \text{Fan Power Correction} + \text{Pump Power Correction}) \\ &= \text{Watts/Watts} \\ &= (65,969/3.412)/(5,960 - 470 + 41) \\ &= 3.50 \text{ Watts/Watt} \\ &= 11.9 \text{ Btuh/Watt} \end{aligned}$$

### g) Perform Heating Capacity Calculation

Use the following formula to calculate heating capacity:

$$\begin{aligned} \text{ISO Heating Capacity} &= (\text{Heating Capacity}) - (\text{Fan Power Correction} \times 3.412) \\ &= 86,000 - (470 \times 3.412) \\ &= 84,396 \text{ Btuh} \end{aligned}$$

### h) Perform Heating COP Calculation

$$\begin{aligned} \text{ISO EER} &= (\text{ISO Heating Capacity}/3.412)/(\text{Heating Power Input} - \text{Fan Power Correction} + \text{Pump Power Correction}) \\ &= \text{Watts/Watts} \\ &= (86,000/3.412)/(5,500 - 470 + 41) \\ &= 4.97 \text{ Watts/Watt} \\ &= 17.0 \text{ Btuh/Watt} \end{aligned}$$

# Performance data



## CORRECTION FACTORS — ANTI-FREEZE

ANTI-FREEZE TYPE	% SOLUTION	COOLING			HEATING		WPD CORRECTION FACTOR (EWT 30 F)
		TC	TSC	kW	TC	kW	
WATER	0	1.000	1.000	1.000	—	—	—
PROPYLENE GLYCOL	5	0.995	0.995	1.003	0.989	0.997	1.070
	15	0.986	0.986	1.009	0.968	0.990	1.210
	25	0.978	0.978	1.014	0.947	0.983	1.360
METHANOL	5	0.995	0.995	1.002	0.989	0.997	1.070
	15	0.990	0.990	1.007	0.968	0.990	1.160
	25	0.982	0.982	1.012	0.949	0.984	1.220
ETHANOL	5	0.998	0.998	1.002	0.981	0.994	1.140
	15	0.994	0.994	1.005	0.944	0.983	1.300
	25	0.986	0.986	1.009	0.917	0.974	1.360
ETHYLENE GLYCOL	5	0.998	0.998	1.002	0.993	0.998	1.040
	15	0.994	0.994	1.004	0.980	0.994	1.120
	25	0.988	0.988	1.008	0.966	0.990	1.200

### LEGEND

EWT — Entering Water Temperature  
 kW — Total Power (Kilowatts)  
 TC — Total Capacity (MBtuh)

TSC — Total Sensible Capacity (MBtuh)  
 WPD — Water-side Pressure Drop

## CORRECTION FACTORS — ENTERING AIR

EAT WB (F)	TC	COOLING											HEATING				
		Sensible Cooling Capacity Entering DB (F)										kW	THR	EAT DB (F)	TC	kW	THA
		60	65	70	75	80	80.6	85	90	95							
50	0.7335	0.883	*	*	*	*	*	*	*	*	*	0.978	0.783	50	1.044	0.834	1.099
55	0.8063	0.676	0.884	1.112	*	*	*	*	*	*	*	0.984	0.842	55	1.034	0.872	1.076
60	0.8830	—	0.673	0.882	1.092	*	*	*	*	*	*	0.990	0.930	60	1.024	0.910	1.053
65	0.9774	—	—	0.668	0.876	1.089	1.114	1.295	*	*	*	0.997	0.998	65	1.012	0.955	1.027
66.2	0.9851	—	—	0.618	0.824	1.036	1.061	1.245	*	*	*	0.999	0.988	68	1.005	0.982	1.011
67	1.0000	—	—	0.584	0.790	1.000	1.026	1.212	*	*	*	1.000	1.000	70	1.000	1.000	1.000
70	1.0426	—	—	—	0.661	0.869	0.894	1.081	1.292	*	*	1.004	1.042	75	0.989	1.047	0.974
75	1.1386	—	—	—	—	0.652	0.652	0.859	1.069	1.284	*	1.012	1.113	80	0.974	1.101	0.942

### LEGEND

AHRI — Air Conditioning, Heating, and Refrigeration Institute  
 ASHRAE — American Society of Heating, Refrigeration and Air Conditioning Engineers  
 db — Dry Bulb  
 EAT — Entering-Air Temperature (F)  
 ISO — International Organization for Standardization  
 kW — Total Power Input (kilowatts)  
 TC — Total Capacity  
 THA — Total Heat of Absorption  
 THR — Total Heat of Rejection  
 TSC — Total Sensible Capacity  
 wb — Wet Bulb

### NOTES:

- ARI/ISO/ASHRAE 13256-1 uses entering air conditions of Cooling — 80.6 F db/66.2 F wb and Heating — 68 F db/59 F wb.
- Discontinued Standards ARI 320, 325, and 330 used entering air conditions of Cooling 80 F db/67 F wb and Heating — 70 F db (bold print for comparison only).

## CORRECTION FACTORS — NOMINAL CFM

AIRFLOW		COOLING				HEATING		
CFM Nominal Per Ton	% of Nominal	TC	TSC	kW	THR	TC	kW	THA
300	75%	0.957	0.869	0.951	0.955	0.970	1.054	0.964
325	81%	0.966	0.901	0.963	0.966	0.978	1.035	0.975
350	88%	0.976	0.933	0.974	0.976	0.986	1.017	0.987
375	94%	0.988	0.966	0.987	0.988	0.993	1.009	0.993
400	100%	1.000	1.000	1.000	1.000	1.000	1.000	1.000
425	106%	1.006	1.029	1.014	1.008	1.006	0.999	1.005
450	113%	1.012	1.058	1.027	1.015	1.012	0.997	1.010
475	119%	1.017	1.080	1.051	1.024	1.017	0.996	1.014
500	125%	1.022	1.103	1.074	1.033	1.022	0.996	1.019

NOTE: 400 CFM per ton is Nominal Airflow.

## ENGLISH TO SI CONVERSIONS

AIRFLOW	Airflow (L/s) = CFM x 0.472
WATER FLOW	Water Flow (L/s) = gpm x 0.0631
EXTERNAL STATIC PRESSURE (ESP)	ESP (Pa) = ESP (in. wg) x 249
WATER PRESSURE DROP (PD)	PD (kPa) = PD (ft of hd) x 2.99

# Performance data (cont)



## 50HQP072 2400 CFM NOMINAL AIRFLOW

EWT (F)	GPM	PRESSURE DROP		COOLING CAPACITY					HEATING CAPACITY				
		PSIG	FT WG	TC	TSC	kW	THR	EER	HC	kW	THA	LAT	COP
20	20	6.8	15.8	Operation Not Recommended					49.5	5.0	32.5	87.1	2.9
30	10	1.2	2.7	82.3	56.8	3.6	94.5	23.0	54.7	5.0	37.5	89.0	3.2
	15	3.3	7.7	81.1	55.8	3.4	92.8	23.6	56.8	5.1	39.6	89.9	3.3
	20	6.2	14.3	80.2	55.1	3.4	91.7	23.8	58.0	5.1	40.7	90.3	3.4
40	10	1.0	2.2	82.4	57.4	3.9	95.6	21.2	63.2	5.1	45.6	92.3	3.6
	15	3.0	7.0	82.6	57.1	3.7	95.1	22.4	66.1	5.2	48.4	93.4	3.7
	20	5.6	13.0	82.4	56.8	3.6	94.6	22.9	67.7	5.2	50.0	94.1	3.8
50	10	0.9	2.0	80.7	57.2	4.2	95.1	19.0	72.3	5.3	54.4	95.8	4.0
	15	2.8	6.5	81.9	57.4	4.0	95.6	20.5	76.0	5.3	57.8	97.2	4.2
	20	5.3	12.2	82.3	57.4	3.9	95.6	21.1	78.0	5.4	59.7	98.0	4.3
60	10	0.5	1.2	77.7	56.3	4.7	93.6	16.7	81.8	5.4	63.3	99.5	4.4
	15	2.2	5.1	79.7	56.9	4.4	94.7	18.2	86.0	5.5	67.2	101.1	4.6
	20	4.4	10.1	80.6	57.2	4.3	95.1	18.9	88.3	5.5	69.4	102.0	4.7
70	10	0.5	1.1	73.9	54.9	5.2	91.4	14.3	91.1	5.6	72.0	103.1	4.8
	15	2.1	4.8	76.3	55.8	4.8	92.8	15.8	95.6	5.7	76.3	104.8	4.9
	20	4.2	9.6	77.5	56.2	4.69	93.5	16.5	98.0	5.7	78.5	105.7	5.0
80	10	0.4	0.9	69.4	53.1	5.71	88.9	12.2	99.8	5.8	80.2	106.4	5.1
	15	1.9	4.5	72.2	54.2	5.37	90.5	13.4	104.4	5.9	84.4	108.2	5.2
	20	3.9	9.1	73.5	54.7	5.20	91.2	14.1	106.7	5.9	86.5	109.1	5.3
85	10	0.4	0.8	67.1	52.1	6.03	87.7	11.2	103.7	5.8	83.8	107.9	5.2
	15	1.9	4.4	69.8	53.3	5.66	89.2	12.4	108.0	5.9	87.8	109.6	5.3
	20	3.9	8.9	71.2	53.8	5.49	89.9	13.0	110.1	6.0	89.7	110.4	5.4
90	10	0.3	0.8	64.8	51.2	6.35	86.4	10.2	107.6	5.9	87.4	109.4	5.3
	15	1.8	4.3	67.5	52.3	5.96	87.9	11.3	111.7	6.0	91.1	111.0	5.4
	20	3.8	8.8	68.9	52.9	5.78	88.6	11.9	113.5	6.0	92.8	111.7	5.5
100	10	0.3	0.7	60.1	49.2	7.06	84.2	8.5	Operation Not Recommended				
	15	1.8	4.1	62.7	50.3	6.64	85.4	9.4					
	20	3.7	8.5	64.1	50.9	6.44	86.1	10.0					
110	10	0.2	0.6	55.8	47.5	7.87	82.7	7.1					
	15	1.7	3.9	58.1	48.4	7.41	83.4	7.8					
	20	3.6	8.3	59.4	48.9	7.19	83.9	8.3					
120	10	0.2	0.5	52.2	46.3	8.78	82.2	5.9					
	15	1.6	3.7	54.1	46.9	8.27	82.3	6.5					
	20	3.5	8.0	55.1	47.3	8.02	82.5	6.9					

### LEGEND

See below

- COP** — Coefficient of Performance
- EER** — Energy Efficiency Ratio
- EWT** — Entering Water Temperature
- GPM** — Gallons Per Minute
- HC** — Heating Capacity
- kW** — Total Power (Kilowatts)
- LAT** — Leaving Air Temperature
- MBtuh** — Btuh in Thousands
- TC** — Total Capacity (MBtuh)
- THA** — Total Heat of Absorption (MBtuh)
- THR** — Total Heat of Rejection (MBtuh)
- TSC** — Total Sensible Capacity (MBtuh)

### NOTES:

1. Interpolation is permissible, extrapolation is not.
2. All entering air conditions are 80 F db (dry bulb) and 67 F wb (wet bulb) in cooling and 70 F db in heating.
3. AHRI/ISO certified conditions are 80.6 F db and 66.2 F wb in cooling and 68 F db in heating.
4. Table does not reflect fan or pump power corrections for AHRI/ISO conditions.
5. All performance data is based upon the lower voltage of dual voltage rated units.
6. Performance stated is at the rated power supply. Performance may vary as the power supply varies from the rated voltage.
7. Operation below 60 F EWT requires optional insulated water circuit.
8. Operation below 40 F EWT is based upon 15% methanol antifreeze solution.
9. See Correction Factor tables for operating conditions other than those listed above.
10. Performance capacities shown in MBtuh.

### OPERATION IN SHADED AREAS

For operation in the shaded area when water is used in lieu of an anti-freeze solution, the LWT (Leaving Water Temperature) must be calculated. Flow must be maintained to a level such that the LWT is maintained above 42 F [5.6 C] when operating in the standard range. This is due to the potential of the refrigerant temperature being as low as 32 F [0° C] with 40 F [4.4 C] LWT, which may lead to a nuisance cutout due to the activation of the Low Temperature Protection.

Example:

At 50 F EWT (Entering Water Temperature) and 15 gpm, a 50HQP072 unit has a THA of 57,800 Btuh. To calculate LWT, rearrange the formula for THA as follows: THA = TD x GPM x 500, where THA = Total Heat of Absorption (Btuh); TD = temperature difference (EWT - LWT) and GPM = U.S. Gallons per Minute.

$$TD = THA / (GPM \times 500)$$

$$TD = 57,800 / (15 \times 500)$$

$$TD = 8 \text{ F}$$

$$LWT = EWT - TD$$

$$LWT = 50 - 8 = 42 \text{ F}$$

In this example, a higher flow rate will be required for EWTs at or below 50 F without antifreeze.



**50HQP096**  
**3200 CFM NOMINAL AIRFLOW**

EWT (F)	GPM	PRESSURE DROP		COOLING CAPACITY					HEATING CAPACITY				
		PSI	FT WG	TC	TSC	kW	THR	EER	TC	kW	THA	LAT	COP
20	24	10.2	23.5	Operation Not Recommended					67.1	6.60	44.6	87.4	3.0
30	12	2.1	4.9	109.6	77.9	4.9	126.2	22.4	73.6	6.73	50.7	89.3	3.2
	18	5.3	12.1	109.3	77.9	4.7	125.3	23.3	76.9	6.79	53.7	90.2	3.3
	24	9.3	21.4	108.9	77.8	4.6	124.6	23.7	78.7	6.83	55.4	90.7	3.4
40	12	1.9	4.4	108.7	77.3	5.3	126.7	20.7	84.8	6.95	61.1	92.5	3.6
	18	4.8	11.0	109.5	77.8	5.0	126.5	21.9	89.0	7.03	65.1	93.7	3.7
	24	8.4	19.3	109.6	77.9	4.9	126.2	22.5	91.4	7.07	67.3	94.4	3.8
50	12	1.7	4.0	106.7	76.2	5.7	126.2	18.7	96.7	7.17	72.2	95.9	4.0
	18	4.5	10.3	108.2	77.0	5.4	126.6	20.1	101.9	7.27	77.1	97.4	4.1
	24	7.9	18.2	108.8	77.3	5.2	126.7	20.8	104.7	7.32	79.8	98.2	4.2
60	12	1.5	3.4	103.6	74.8	6.3	124.9	16.5	108.8	7.40	83.6	99.4	4.3
	18	3.8	8.8	105.8	75.8	5.9	125.9	18.0	114.9	7.51	89.3	101.2	4.5
	24	6.8	15.8	106.8	76.3	5.7	126.2	18.8	118.2	7.58	92.4	102.1	4.6
70	12	1.3	3.1	99.6	73.1	6.9	123.1	14.5	121.0	7.63	95.0	102.9	4.6
	18	3.6	8.4	102.4	74.3	6.5	124.4	15.9	127.7	7.76	101.2	104.9	4.8
	24	6.6	15.2	103.7	74.9	6.2	125.0	16.6	131.3	7.83	104.6	105.9	4.9
80	12	1.2	2.8	94.9	71.1	7.6	120.9	12.5	132.8	7.86	106.0	106.3	5.0
	18	3.4	7.9	98.2	72.5	7.1	122.4	13.8	139.8	8.01	112.5	108.4	5.1
	24	6.3	14.5	99.7	73.1	6.9	123.2	14.5	143.5	8.09	115.9	109.4	5.2
85	12	1.1	2.7	92.3	70.0	8.0	119.6	11.6	138.3	7.98	111.1	107.9	5.1
	18	3.4	7.7	95.7	71.4	7.5	121.3	12.8	145.3	8.13	117.5	109.9	5.2
	24	6.2	14.2	97.3	72.1	7.2	122.0	13.5	148.8	8.21	120.8	111.0	5.3
90	12	1.1	2.5	89.6	68.9	8.4	118.4	10.6	143.9	8.10	116.2	109.5	5.2
	18	3.3	7.6	93.2	70.4	7.9	120.1	11.8	150.8	8.25	122.6	111.5	5.4
	24	6.1	14.0	94.9	71.1	7.6	120.9	12.5	154.2	8.34	125.7	112.5	5.4
100	12	1.0	2.3	83.9	66.6	9.3	115.7	9.0	Operation Not Recommended				
	18	3.1	7.2	87.7	68.1	8.7	117.5	10.0					
	24	5.9	13.6	89.6	68.9	8.4	118.3	10.6					
110	12	0.9	2.0	77.8	64.0	10.4	113.1	7.5					
	18	3.0	6.8	81.7	65.7	9.7	114.8	8.4					
	24	5.7	13.1	83.7	66.5	9.4	115.6	8.9					
120	12	0.8	1.8	71.5	61.2	11.5	110.6	6.2					
	18	2.8	6.5	75.4	63.0	10.8	112.2	7.0					
	24	5.5	12.6	77.4	63.8	10.4	113.0	7.4					

**LEGEND**

See below

- COP** — Coefficient of Performance
- EER** — Energy Efficiency Ratio
- EWT** — Entering Water Temperature
- GPM** — Gallons Per Minute
- HC** — Heating Capacity
- kW** — Total Power (Kilowatts)
- LAT** — Leaving Air Temperature
- MBtuh** — Btuh in Thousands
- TC** — Total Capacity (MBtuh)
- THA** — Total Heat of Absorption (MBtuh)
- THR** — Total Heat of Rejection (MBtuh)
- TSC** — Total Sensible Capacity (MBtuh)

**NOTES:**

1. Interpolation is permissible, extrapolation is not.
2. All entering air conditions are 80 F db (dry bulb) and 67 F wb (wet bulb) in cooling and 70 F db in heating.
3. AHRI/ISO certified conditions are 80.6 F db and 66.2 F wb in cooling and 68 F db in heating.
4. Table does not reflect fan or pump power corrections for AHRI/ISO conditions.
5. All performance data is based upon the lower voltage of dual voltage rated units.
6. Performance stated is at the rated power supply. Performance may vary as the power supply varies from the rated voltage.
7. Operation below 60 F EWT requires optional insulated water circuit.
8. Operation below 40 F EWT is based upon 15% methanol antifreeze solution.
9. See Correction Factor tables for operating conditions other than those listed above.
10. Performance capacities shown in MBtuh.

**OPERATION IN SHADED AREAS**

For operation in the shaded area when water is used in lieu of an anti-freeze solution, the LWT (Leaving Water Temperature) must be calculated. Flow must be maintained to a level such that the LWT is maintained above 42 F [5.6 C] when operating in the standard range. This is due to the potential of the refrigerant temperature being as low as 32 F [0° C] with 40 F [4.4 C] LWT, which may lead to a nuisance cutout due to the activation of the Low Temperature Protection.

Example:

At 50 F EWT (Entering Water Temperature) and 15 gpm, a 50HQP072 unit has a THA of 57,800 Btuh. To calculate LWT, rearrange the formula for THA as follows: THA = TD x GPM x 500, where THA = Total Heat of Absorption (Btuh); TD = temperature difference (EWT - LWT) and GPM = U.S. Gallons per Minute.

$$TD = THA / (GPM \times 500)$$

$$TD = 57,800 / (15 \times 500)$$

$$TD = 8 F$$

$$LWT = EWT - TD$$

$$LWT = 50 - 8 = 42 F$$

In this example, a higher flow rate will be required for EWTs at or below 50 F without antifreeze.

# Performance data (cont)



## 50HQP120 4000 CFM NOMINAL AIRFLOW

EWT (F)	GPM	PRESSURE DROP		COOLING CAPACITY					HEATING CAPACITY				
		PSI	FT WG	TC	TSC	kW	THR	EER	TC	kW	THA	LAT	COP
20	30	16.0	36.9	Operation Not Recommended					91.8	9.0	61.1	89.2	3.0
30	15	4.0	9.2	141.5	98.1	6.6	163.9	21.6	99.2	9.2	67.8	90.9	3.2
	23	8.6	19.9	140.4	98.2	6.3	162.0	22.2	103.3	9.3	71.6	91.9	3.3
	30	14.5	33.4	139.2	98.0	6.2	160.5	22.4	105.6	9.4	73.7	92.4	3.3
40	15	3.5	8.0	140.6	97.2	7.0	164.4	20.1	112.5	9.5	80.1	94.0	3.5
	23	7.7	17.8	141.5	98.0	6.7	164.2	21.3	117.8	9.6	84.9	95.2	3.6
	30	13.0	30.0	141.5	98.2	6.5	163.7	21.7	120.8	9.7	87.6	95.9	3.6
50	15	3.2	7.4	137.4	95.6	7.5	163.0	18.3	126.8	9.9	93.2	97.3	3.8
	23	7.2	16.6	139.9	96.8	7.1	164.1	19.7	133.3	10.0	99.2	98.8	3.9
	30	12.2	28.3	140.8	97.3	6.9	164.4	20.3	136.9	10.1	102.5	99.6	4.0
60	15	2.4	5.5	132.6	93.5	8.1	160.3	16.3	141.7	10.2	106.9	100.7	4.1
	23	5.8	13.4	136.2	95.0	7.7	162.4	17.7	149.3	10.4	114.0	102.5	4.2
	30	10.2	23.6	137.7	95.8	7.5	163.2	18.5	153.6	10.5	117.9	103.5	4.3
70	15	2.2	5.1	126.6	90.9	8.9	156.9	14.3	156.8	10.5	120.9	104.2	4.4
	23	5.5	12.7	130.9	92.8	8.3	159.4	15.7	165.6	10.7	129.0	106.2	4.5
	30	9.8	22.6	133.0	93.6	8.1	160.6	16.4	170.4	10.8	133.4	107.3	4.6
80	15	2.1	4.7	119.9	88.0	9.7	153.1	12.3	172.0	10.9	135.0	107.7	4.6
	23	5.2	12.0	124.6	90.0	9.1	155.7	13.7	181.6	11.1	143.8	110.0	4.8
	30	9.4	21.7	126.9	91.0	8.8	157.1	14.4	186.9	11.2	148.6	111.2	4.9
85	15	2.0	4.6	116.4	86.5	10.2	151.2	11.5	179.5	11.0	141.9	109.5	4.8
	23	5.1	11.9	121.1	88.5	9.6	153.8	12.7	189.4	11.3	151.0	111.7	4.9
	30	9.3	21.5	123.5	89.6	9.3	155.1	13.4	194.8	11.4	155.8	113.0	5.0
90	15	2.0	4.5	113.0	85.0	10.7	149.3	10.6	187.0	11.2	148.7	111.2	4.9
	23	5.1	11.7	117.7	87.0	10.0	151.8	11.8	197.2	11.5	158.1	113.5	5.0
	30	9.2	21.2	120.1	88.1	9.7	153.2	12.4	202.7	11.6	163.1	114.8	5.1
100	15	1.9	4.3	106.0	81.8	11.7	146.0	9.0	Operation Not Recommended				
	23	4.9	11.4	110.6	83.9	11.0	148.1	10.0					
	30	9.0	20.8	112.9	84.9	10.7	149.3	10.6					
110	15	1.8	4.1	99.6	78.9	12.9	143.6	7.7					
	23	4.8	11.1	103.7	80.8	12.1	145.0	8.6					
	30	8.8	20.4	105.9	81.8	11.8	145.9	9.0					
120	15	1.7	3.9	94.2	76.5	14.2	142.6	6.6					
	23	4.7	10.8	97.5	78.0	13.4	143.1	7.3					
	30	8.6	19.9	99.4	78.8	13.0	143.5	7.7					

### LEGEND

See below

- COP** — Coefficient of Performance
- EER** — Energy Efficiency Ratio
- EWT** — Entering Water Temperature
- GPM** — Gallons Per Minute
- HC** — Heating Capacity
- kW** — Total Power (Kilowatts)
- LAT** — Leaving Air Temperature
- MBtuh** — Btuh in Thousands
- TC** — Total Capacity (MBtuh)
- THA** — Total Heat of Absorption (MBtuh)
- THR** — Total Heat of Rejection (MBtuh)
- TSC** — Total Sensible Capacity (MBtuh)

### NOTES:

1. Interpolation is permissible, extrapolation is not.
2. All entering air conditions are 80 F db (dry bulb) and 67 F wb (wet bulb) in cooling and 70 F db in heating.
3. AHRI/ISO certified conditions are 80.6 F db and 66.2 F wb in cooling and 68 F db in heating.
4. Table does not reflect fan or pump power corrections for AHRI/ISO conditions.
5. All performance data is based upon the lower voltage of dual voltage rated units.
6. Performance stated is at the rated power supply. Performance may vary as the power supply varies from the rated voltage.
7. Operation below 60 F EWT requires optional insulated water circuit.
8. Operation below 40 F EWT is based upon 15% methanol antifreeze solution.
9. See Correction Factor tables for operating conditions other than those listed above.
10. Performance capacities shown in MBtuh.

### OPERATION IN SHADED AREAS

For operation in the shaded area when water is used in lieu of an anti-freeze solution, the LWT (Leaving Water Temperature) must be calculated. Flow must be maintained to a level such that the LWT is maintained above 42 F [5.6 C] when operating in the standard range. This is due to the potential of the refrigerant temperature being as low as 32 F [0° C] with 40 F [4.4 C] LWT, which may lead to a nuisance cutout due to the activation of the Low Temperature Protection.

Example:

At 50 F EWT (Entering Water Temperature) and 15 gpm, a 50HQP072 unit has a THA of 57,800 Btuh. To calculate LWT, rearrange the formula for THA as follows:  
 $THA = TD \times GPM \times 500$ , where THA = Total Heat of Absorption (Btuh); TD = temperature difference (EWT - LWT) and GPM = U.S. Gallons per Minute.

$$TD = THA / (GPM \times 500)$$

$$TD = 57,800 / (15 \times 500)$$

$$TD = 8 \text{ F}$$

$$LWT = EWT - TD$$

$$LWT = 50 - 8 = 42 \text{ F}$$

In this example, a higher flow rate will be required for EWTs at or below 50 F without antifreeze.



### 50HQ072 BLOWER DATA

RATED CFM		EXTERNAL STATIC PRESSURE (in. wg)															
		0.0	0.1	0.2	0.3	0.4	0.5	0.6	0.7	0.8	0.9	1.0	1.1	1.2	1.3	1.4	1.5
1800	BHP	—	—	0.28	0.32	0.35	0.39	0.42	0.45	0.48	0.52	0.56	0.60	0.64	0.69	0.72	0.76
	Motor Type	—	—	B	B	B	A	A	A	A	A	A	C	C	C	C	C
	RPM	—	—	599	645	690	735	775	815	850	885	910	940	965	995	1015	1040
	Turns Open	—	—	3	2	1	4	3.5	2.5	2	1.5	1	5	4.5	4	3.5	3
1900	BHP	—	—	0.31	0.36	0.40	0.44	0.49	0.53	2.50	0.62	0.65	0.69	0.73	0.76	0.80	0.84
	Motor Type	—	—	B	B	A	A	A	A	A	A	C	C	C	C	C	C
	RPM	—	—	604	655	695	740	780	820	855	890	920	950	980	1005	1030	1055
	Turns Open	—	—	3	2	5	4	3	2.5	2	1.5	5.5	4.5	4	3.5	3	3
2000	BHP	—	0.31	0.34	0.39	0.45	0.50	0.54	0.59	0.63	0.67	0.72	0.75	0.79	0.82	0.86	0.90
	Motor Type	—	B	B	B	A	A	A	A	A	A	C	C	C	C	C	C
	RPM	—	568	615	660	705	750	785	825	860	895	930	960	990	1015	1040	1065
	Turns Open	—	4.5	2.5	1.5	4.5	3.5	3	2.5	1.5	1	5	4.5	4	3.5	3	2.5
2100	BHP	0.33	0.38	0.42	0.46	0.50	0.54	0.59	0.65	0.70	0.74	0.78	0.81	0.85	0.89	0.94	0.98
	Motor Type	B	B	B	A	A	A	A	A	A	A	C	C	C	C	C	C
	RPM	531	583	630	670	715	755	795	835	875	905	940	970	1000	1025	1055	1080
	Turns Open	4.5	3.5	2	5	4.5	3.5	2.5	2	1.5	1	5	4	4	3	2.5	2.5
2200	BHP	0.37	0.40	0.45	0.49	0.55	0.60	0.65	0.70	0.75	0.79	0.83	0.87	0.92	0.96	1.00	1.04
	Motor Type	B	B	B	A	A	A	A	A	A	C	C	C	C	C	E	E
	RPM	552	599	645	685	730	770	810	850	885	915	950	980	1010	1040	1065	1090
	Turns Open	4	3	2	5	4	3	2.5	2	1.5	5.5	4.5	4	3.5	3	2.5	2
2300	BHP	0.42	0.47	0.51	0.56	0.60	0.65	0.70	0.75	0.80	0.84	0.89	0.94	1.00	1.05	1.10	1.16
	Motor Type	B	B	B	A	A	A	A	A	A	C	C	C	E	E	E	E
	RPM	573	620	660	705	745	785	820	860	895	925	960	990	1020	1050	1075	1105
	Turns Open	3.5	2.5	1.5	4.5	4	3	2.5	1.5	1	5	4.5	4	3.5	3	2.5	2
2400	BHP	0.48	0.52	0.57	0.61	0.66	0.72	0.78	0.83	0.87	0.92	0.97	1.02	1.07	1.13	1.19	1.25
	Motor Type	B	B	A	A	A	A	A	A	A	C	C	E	E	E	E	E
	RPM	604	645	690	730	765	805	845	880	910	945	975	1010	1035	1065	1095	1125
	Turns Open	3	2	5	4	3.5	2.5	2	1.5	1	5	4	3.5	3	2.5	2	1.5
2500	BHP	0.52	0.57	0.61	0.66	0.72	0.78	0.83	0.89	0.94	1.00	1.03	1.08	1.14	1.20	1.25	1.31
	Motor Type	B	B	A	A	A	A	A	A	C	E	E	E	E	E	E	E
	RPM	620	660	700	740	780	815	850	885	920	950	985	1015	1045	1075	1100	1130
	Turns Open	2.5	1.5	4.5	4	3	2.5	2	1.5	5.5	4.5	4	3.5	3	2.5	2	1.5
2600	BHP	0.56	0.61	0.66	0.70	0.76	0.82	0.88	0.93	0.98	1.04	1.08	1.14	1.20	1.26	1.32	1.37
	Motor Type	B	A	A	A	A	A	A	A	C	E	E	E	E	E	E	E
	RPM	635	675	715	750	790	825	860	895	925	960	990	1020	1050	1080	1110	1135
	Turns Open	2.5	5	4.5	3.5	3	2	1.5	1	5	4.5	4	3.5	3	2.5	1.5	1.5
2700	BHP	0.61	0.66	0.71	0.76	0.82	0.87	0.93	0.98	1.04	1.10	1.15	1.21	1.27	1.33	1.39	1.45
	Motor Type	B	A	A	A	A	A	A	A	E	E	E	E	E	E	E	E
	RPM	655	695	730	770	805	840	875	905	940	970	1000	1030	1060	1090	1120	1145
	Turns Open	2	4.5	4	3.5	2.5	2	1.5	1	5	4.5	3.5	3	2.5	2	1.5	1
2800	BHP	0.66	0.72	0.77	0.83	0.88	0.93	0.99	1.05	1.11	1.16	1.22	1.30	1.37	1.44	1.51	1.57
	Motor Type	B	A	A	A	A	A	A	D	E	E	E	E	E	E	E	E
	RPM	670	710	750	785	815	850	885	915	950	980	1010	1040	1070	1100	1130	1155
	Turns Open	1.5	4.5	3.5	3	2.5	1.5	1.5	1	4.5	4	3.5	3	2.5	2	1.5	1
2900	BHP	0.71	0.77	0.82	0.87	0.93	0.98	1.04	1.10	1.16	1.22	1.30	1.36	1.43	1.50	1.57	1.63
	Motor Type	A	A	A	A	A	A	D	E	E	E	E	E	E	E	E	E
	RPM	685	725	765	795	830	860	895	925	955	985	1020	1045	1075	1105	1135	1160
	Turns Open	5	4	3.5	3	2	1.5	1	5	4.5	4	3.5	3	2.5	1.5	1	1
3000	BHP	0.79	0.84	0.90	0.95	1.01	1.07	1.13	1.19	1.25	1.31	1.38	1.46	1.52	1.59	1.66	—
	Motor Type	A	A	A	A	A	D	D	E	E	E	E	E	E	E	E	—
	RPM	710	745	780	815	850	885	915	945	975	1005	1035	1065	1090	1120	1150	—
	Turns Open	4.5	4	3	2.5	2	1	1	5	4	3.5	3	2.5	2	1.5	1	—

**LEGEND**

- — Operation Not Recommended
- BHP** — Brake Horsepower
- ESP** — External Static Pressure
- RPM** — Revolutions Per Minute
- A** — Units with Standard Static/Standard Motor Option
- B** — Units with Low Static/Standard Motor Option
- C** — Units with High Static/Standard Motor Option
- D** — Units with Standard Static/Large Motor Option
- E** — Units with High Static/Large Motor Option

**NOTES:**

1. Units factory shipped with standard static sheave and drive at 2.5 turns open (2400 cfm at 0.5 in. wg ESP Wet Coil). Other speeds require field selection.

2. ISO/AHRI rating point with standard static sheave and drive at 3.5 turns open (2400 cfm at 0.5 in. wg ESP Wet Coil). Other speeds require field selection.
3. For applications requiring higher static pressures, contact your local representative.
4. Based on standard 12x12 blower.
5. Performance data does not include drive losses and is based on sea level conditions.
6. All airflow is rated at lowest voltage if unit is dual voltage rated, i.e., 208 V for 208-230 V units.
7. For wet coil performance first calculate the face velocity of the air coil (Face Velocity [fpm] = Airflow [cfm] / Face Area [sq ft]). Then for velocities of 200 fpm reduce the static capability by 0.03 in. wg, 300 fpm by 0.08 in. wg, 400 fpm by 0.12 in. wg and 500 fpm by 0.16 in. wg.
8. Large motor size is 2 hp for 50HQ072.

# Performance data (cont)



## 50HQ096 BLOWER DATA

RATED CFM		EXTERNAL STATIC PRESSURE (in. wg)															
		0.0	0.1	0.2	0.3	0.4	0.5	0.6	0.7	0.8	0.9	1.0	1.1	1.2	1.3	1.4	1.5
2400	BHP	0.45	0.5	0.54	0.59	0.63	0.69	0.74	0.8	0.85	0.9	0.94	0.99	1.04	1.1	1.16	1.22
	Motor Type	B	B	B	B	B	A	A	A	A	A	A	A	A	A	C	C
	RPM	578	625	665	705	745	785	820	860	895	925	960	990	1020	1050	1080	1110
2500	Turns Open	5	4	3	2.5	1.5	5.5	5	4	3.5	3	2.5	2	1.5	1	4	3.5
	BHP	0.5	0.55	0.59	0.64	0.69	0.75	0.81	0.88	0.92	0.97	1.01	1.06	1.12	1.17	1.23	1.29
	Motor Type	B	B	B	B	A	A	A	A	A	A	A	A	A	C	C	C
2600	RPM	599	645	685	725	765	800	835	875	905	940	970	1005	1035	1060	1090	1120
	Turns Open	4.5	3.5	2.5	2	6	5	4.5	4	3.5	3	2.5	2	1	4.5	3.5	3
	BHP	0.55	0.6	0.65	0.69	0.75	0.8	0.86	0.92	0.97	1.02	1.08	1.13	1.19	1.25	1.3	1.36
2700	Motor Type	B	B	B	B	A	A	A	A	A	A	A	A	A	C	C	C
	RPM	625	665	705	740	780	815	850	885	920	950	985	1015	1045	1075	1100	1130
	Turns Open	4	3	2.5	1.5	5.5	5	4.5	3.5	3	2.5	2	1.5	1	4	3.5	3
2800	BHP	0.6	0.65	0.7	0.75	0.8	0.86	0.91	0.97	1.02	1.08	1.14	1.2	1.26	1.32	1.38	1.44
	Motor Type	B	B	B	A	A	A	A	A	A	A	A	A	C	C	C	C
	RPM	645	685	725	760	795	830	865	900	930	960	995	1025	1055	1085	1115	1140
2900	Turns Open	3.5	2.5	2	6	5.5	4.5	4	3.5	3	2.5	2	1.5	4.5	3.5	3	3
	BHP	0.65	0.71	0.76	0.82	0.87	0.93	0.98	1.04	1.1	1.16	1.21	1.28	1.36	1.43	1.5	1.56
	Motor Type	B	B	B	A	A	A	A	A	A	A	A	A	C	C	C	C
3000	RPM	665	705	745	780	810	845	880	910	945	975	1005	1035	1065	1095	1125	1150
	Turns Open	3	2.5	1.5	5.5	5	4.5	4	3	2.5	2	1.5	1	4	3.5	3	2.5
	BHP	0.71	0.76	0.82	0.87	0.92	0.98	1.03	1.09	1.16	1.22	1.29	1.36	1.43	1.5	1.57	1.63
3100	Motor Type	B	B	A	A	A	A	A	A	A	A	A	A	C	C	C	C
	RPM	685	720	760	795	825	860	890	920	955	985	1015	1045	1075	1105	1135	1160
	Turns Open	2.5	2	6	5.5	5	4	3.5	3	2.5	2	1.5	1	4	3.5	3	2.5
3200	BHP	0.78	0.84	0.89	0.95	1	1.06	1.12	1.18	1.24	1.3	1.37	1.43	1.5	1.58	1.64	1.71
	Motor Type	B	B	A	A	A	A	A	A	A	A	A	C	C	C	C	C
	RPM	700	740	775	810	845	880	910	940	970	1000	1030	1055	1085	1115	1140	1170
3300	Turns Open	2.5	1.5	5.5	5	4.5	4	3.5	2.5	2	1.5	1	4.5	3.5	3	2.5	2.5
	BHP	0.85	0.91	0.96	1.02	1.08	1.14	1.22	1.29	1.36	1.44	1.5	1.57	1.63	1.7	1.76	1.82
	Motor Type	B	B	A	A	A	A	A	A	A	A	A	C	C	C	C	C
3400	RPM	720	755	790	825	860	890	925	955	985	1015	1040	1070	1095	1125	1150	1175
	Turns Open	2	1	5.5	4.5	4	3.5	3	2.5	2	1.5	1	4	3.5	3	2.5	2
	BHP	0.93	1	1.07	1.14	1.2	1.26	1.32	1.38	1.44	1.51	1.57	1.64	1.7	1.78	1.85	1.92
3500	Motor Type	B	A	A	A	A	A	A	A	A	A	C	C	C	C	C	C
	RPM	740	775	810	845	875	905	935	965	995	1025	1050	1080	1105	1135	1160	1185
	Turns Open	1.5	5.5	5	4.5	4	3.5	3	2	1.5	1	4.5	4	3.5	3	2.5	2
3600	BHP	1.01	1.08	1.14	1.21	1.28	1.33	1.39	1.45	1.51	1.58	1.64	1.72	1.78	1.84	1.93	2
	Motor Type	B	A	A	A	A	A	A	A	A	A	C	C	C	C	C	E
	RPM	755	790	820	855	890	915	945	975	1005	1035	1060	1090	1115	1140	1170	1195
3700	Turns Open	1	5.5	5	4	3.5	3	2.5	2	1.5	1	4	3.5	3	2.5	2	2
	BHP	1.08	1.15	1.22	1.29	1.35	1.41	1.47	1.53	1.59	1.68	1.75	1.83	1.9	1.96	2.02	2.08
	Motor Type	A	A	A	A	A	A	A	A	A	A	C	C	C	C	E	E
3800	RPM	765	800	835	870	900	930	960	990	1015	1045	1070	1100	1125	1150	1175	1200
	Turns Open	6	5	4.5	4	3.5	3	2.5	2	1.5	1	4	3.5	3	2.5	2	2
	BHP	1.16	1.23	1.29	1.36	1.42	1.48	1.54	1.6	1.66	1.73	1.79	1.85	1.92	2.01	2.09	2.17
3900	Motor Type	A	A	A	A	A	A	A	A	A	C	C	C	C	E	E	E
	RPM	780	815	845	880	910	940	970	1000	1025	1055	1080	1105	1130	1160	1185	1210
	Turns Open	5.5	5	4.5	3.5	3	2.5	2	1.5	1	4.5	4	3.5	3	2.5	2	1.5
4000	BHP	1.24	1.3	1.37	1.44	1.51	1.58	1.65	1.72	1.78	1.86	1.92	1.98	2.06	2.13	2.21	2.29
	Motor Type	A	A	A	A	A	A	A	A	A	C	C	C	E	E	E	E
	RPM	795	825	860	890	920	950	980	1010	1035	1065	1090	1115	1145	1165	1190	1215
4100	Turns Open	5.5	4.5	4	3.5	3	2.5	2	1.5	1	4	3.5	3	2.5	2	1.5	1.5
	BHP	1.34	1.4	1.46	1.53	1.61	1.68	1.75	1.82	1.9	1.97	2.06	2.13	2.21	2.28	2.36	2.44
	Motor Type	A	A	A	A	A	A	A	A	C	C	E	E	E	E	E	E
4200	RPM	820	850	880	910	940	970	1000	1025	1055	1080	1110	1135	1160	1180	1205	1230
	Turns Open	5	4.5	3.5	3	2.5	2	1.5	1	4.5	4	3.5	3	2.5	2	1.5	1.5
	BHP	1.43	1.49	1.56	1.63	1.7	1.78	1.86	1.94	2.02	2.12	2.2	2.28	2.34	2.42	2.5	2.58
4300	Motor Type	A	A	A	A	A	A	A	A	E	E	E	E	E	E	E	E
	RPM	840	870	900	930	960	990	1020	1045	1070	1100	1125	1150	1170	1195	1220	1245
	Turns Open	4.5	4	3.5	3	2.5	2	1.5	1	4	3.5	3	2.5	2.5	2	1.5	1
4400	BHP	1.58	1.64	1.71	1.78	1.85	1.93	2.01	2.09	2.19	2.27	2.35	2.41	2.49	2.57	2.65	—
	Motor Type	A	A	A	A	A	A	D	D	E	E	E	E	E	E	—	—
	RPM	865	890	920	950	980	1010	1035	1060	1090	1115	1140	1160	1185	1210	1235	—
4500	Turns Open	4	4	3	2.5	2	1.5	1	1	4	3.5	3	2.5	2	1.5	—	—
	BHP	1.68	1.75	1.83	1.92	2	2.08	2.16	2.26	2.34	2.42	2.5	2.56	2.64	2.72	2.8	—
	Motor Type	A	A	A	A	D	D	D	E	E	E	E	E	E	E	E	—
4600	RPM	885	910	940	970	1000	1025	1050	1080	1105	1130	1155	1175	1200	1225	1250	—
	Turns Open	4	3.5	2.5	2.5	2	1	1	4	3.5	3	2.5	2	2	1.5	—	—

### LEGEND

- Operation Not Recommended
- BHP — Brake Horsepower
- ESP — External Static Pressure
- RPM — Revolutions Per Minute
- A — Units with Standard Static/Standard Motor Option
- B — Units with Low Static/Standard Motor Option
- C — Units with High Static/Standard Motor Option
- D — Units with Standard Static/Large Motor Option
- E — Units with High Static/Large Motor Option

### NOTES:

1. Units factory shipped with standard static sheave and drive at 2.5 turns open (3200 cfm at 0.6 in. wg ESP Wet Coil). Other speeds require field selection.

2. ISO/AHRI rating point with standard static sheave and drive at 3.5 turns open (3200 cfm at 0.4 in. wg ESP Wet Coil). Other speeds require field selection.
3. For applications requiring higher static pressures, contact your local representative.
4. Based on standard 12x12 blower.
5. Performance data does not include drive losses and is based on sea level conditions.
6. All airflow is rated at lowest voltage if unit is dual voltage rated, i.e., 208 v for 208-230 v units.
7. For wet coil performance first calculate the face velocity of the air coil (Face Velocity [fpm] = Airflow [cfm] / Face Area [sq ft]). Then for velocities of 200 fpm reduce the static capability by 0.03 in. wg, 300 fpm by 0.08 in. wg, 400 fpm by 0.12 in. wg and 500 fpm by 0.16 in. wg.
8. Large motor size is 3 hp for 50HQ096.



### 50HQ120 BLOWER DATA

RATED CFM		EXTERNAL STATIC PRESSURE (in. wg)															
		0.0	0.1	0.2	0.3	0.4	0.5	0.6	0.7	0.8	0.9	1.0	1.1	1.2	1.3	1.4	1.5
3000	BHP	0.75	0.81	0.86	0.91	0.97	1.03	1.09	1.15	1.21	1.27	1.34	1.41	1.47	1.54	1.61	1.67
	Motor Type	B	B	B	B	B	B	A	A	A	A	A	A	A	A	A	A
	RPM	680	720	755	790	825	860	895	925	955	985	1015	1045	1070	1100	1130	1155
Turns Open		5	4	3.5	3	2.5	1.5	5.5	5	4.5	4	3.5	3	2.5	2	1.5	1
3100	BHP	0.82	0.88	0.94	0.99	1.04	1.1	1.17	1.26	1.33	1.4	1.46	1.53	1.59	1.66	1.72	1.8
	Motor Type	B	B	B	B	B	A	A	A	A	A	A	A	A	A	A	C
	RPM	700	735	775	805	840	875	905	940	970	1000	1025	1055	1080	1110	1135	1165
Turns Open		4.5	4	3	2.5	2	6	5.5	4.5	4.5	3.5	3	2.5	2	2	1.5	4
3200	BHP	0.9	0.96	1.03	1.1	1.17	1.23	1.29	1.35	1.41	1.47	1.55	1.61	1.68	1.74	1.81	1.89
	Motor Type	B	B	B	B	B	A	A	A	A	A	A	A	A	A	A	C
	RPM	720	755	790	825	860	890	920	950	980	1010	1040	1065	1095	1120	1145	1175
Turns Open		4	3.5	3	2	1.5	5.5	5	4.5	4	3.5	3	2.5	2	1.5	1	3.5
3300	BHP	0.98	1.04	1.11	1.18	1.25	1.31	1.37	1.43	1.49	1.55	1.62	1.68	1.75	1.81	1.88	1.95
	Motor Type	B	B	B	B	A	A	A	A	A	A	A	A	A	A	A	C
	RPM	740	770	805	840	875	905	935	965	995	1020	1050	1075	1105	1130	1155	1180
Turns Open		4	3	2.5	2	6	5.5	5	4	4	3	2.5	2.5	2	1.5	1	3.5
3400	BHP	1.06	1.13	1.19	1.26	1.33	1.38	1.44	1.5	1.56	1.65	1.72	1.8	1.87	1.94	2	2.06
	Motor Type	B	B	B	B	A	A	A	A	A	A	A	A	A	A	C	C
	RPM	755	790	820	855	890	915	945	975	1005	1035	1060	1090	1115	1140	1165	1190
Turns Open		3.5	3	2.5	1.5	6	5	4.5	4	3.5	3	2.5	2	1.5	1	4	3
3500	BHP	1.14	1.21	1.27	1.34	1.4	1.46	1.52	1.58	1.65	1.71	1.77	1.84	1.9	1.98	2.06	2.14
	Motor Type	B	B	B	A	A	A	A	A	A	A	A	A	A	A	C	C
	RPM	770	805	835	870	900	930	960	990	1020	1045	1070	1100	1125	1150	1175	1200
Turns Open		3	2.5	2	6	5.5	5	4.5	3.5	3.5	3	2.5	2	1.5	1	3.5	3
3600	BHP	1.23	1.29	1.36	1.42	1.5	1.57	1.64	1.71	1.77	1.84	1.9	1.96	2.05	2.13	2.21	2.27
	Motor Type	B	B	B	A	A	A	A	A	A	A	A	A	A	C	C	C
	RPM	790	820	855	885	915	945	975	1005	1030	1060	1085	1110	1140	1165	1190	1210
Turns Open		3	2.5	1.5	6	5.5	4.5	4	3.5	3	2.5	2	1.5	1.5	4	3.5	3
3700	BHP	1.32	1.38	1.44	1.51	1.58	1.65	1.73	1.81	1.88	1.96	2.03	2.1	2.18	2.26	2.34	2.42
	Motor Type	B	B	A	A	A	A	A	A	A	A	A	A	A	C	C	C
	RPM	810	840	870	900	930	960	990	1020	1045	1075	1100	1125	1150	1175	1200	1225
Turns Open		2.5	2	6	5.5	5	4.5	4	3	3	2.5	2	1.5	1	3.5	3	2.5
3800	BHP	1.41	1.47	1.54	1.61	1.68	1.75	1.82	1.91	1.99	2.07	2.17	2.25	2.31	2.39	2.47	2.55
	Motor Type	B	B	A	A	A	A	A	A	A	A	A	A	A	C	C	C
	RPM	830	860	890	920	950	980	1005	1035	1060	1085	1115	1140	1160	1185	1210	1235
Turns Open		2	1.5	5.5	5	4.5	4	3.5	3	2.5	2	1.5	1	3.5	3	2.5	2.5
3900	BHP	1.54	1.6	1.67	1.74	1.82	1.89	1.96	2.04	2.14	2.22	2.3	2.38	2.46	2.52	2.6	2.68
	Motor Type	B	A	A	A	A	A	A	A	A	A	A	A	C	C	C	C
	RPM	850	875	905	935	965	995	1020	1045	1075	1100	1125	1150	1175	1195	1220	1245
Turns Open		2	6	5.5	5	4.5	3.5	3	2.5	2.5	2	1.5	1	3.5	3	2.5	2
4000	BHP	1.63	1.71	1.78	1.86	1.94	2.03	2.11	2.19	2.27	2.37	2.45	2.51	2.59	2.67	2.75	2.85
	Motor Type	A	A	A	A	A	A	A	A	A	A	A	A	C	C	C	C
	RPM	865	895	920	950	980	1010	1035	1060	1085	1115	1140	1160	1185	1210	1235	1260
Turns Open		6	5.5	5	4.5	4	3.5	3	2.5	2	1.5	1	3.5	3	2.5	2.5	2
4100	BHP	1.73	1.81	1.9	1.97	2.05	2.12	2.2	2.27	2.34	2.42	2.52	2.62	2.7	2.8	2.9	—
	Motor Type	A	A	A	A	A	A	A	A	A	A	C	C	C	C	C	—
	RPM	885	915	945	970	1000	1025	1055	1080	1105	1130	1155	1180	1200	1225	1250	—
Turns Open		6	5.5	4.5	4	4	3	2.5	2	2	1.5	1	3.5	3	2.5	2	—
4200	BHP	1.87	1.94	2.02	2.08	2.16	2.24	2.32	2.4	2.48	2.58	2.68	2.76	2.86	2.96	—	—
	Motor Type	A	A	A	A	A	A	A	A	A	A	C	C	C	C	—	—
	RPM	905	935	965	990	1020	1045	1070	1095	1120	1145	1170	1190	1215	1240	—	—
Turns Open		5.5	5	4.5	4	3.5	3	2.5	2	1.5	1	3.5	3.5	3	2.5	—	—
4300	BHP	2	2.07	2.16	2.23	2.31	2.41	2.49	2.57	2.66	2.74	2.84	2.94	3.02	3.15	—	—
	Motor Type	A	A	A	A	A	A	A	A	A	C	C	C	E	E	—	—
	RPM	930	955	985	1010	1035	1065	1090	1115	1140	1160	1185	1210	1230	1255	—	—
Turns Open		5	4.5	4	3.5	3	2.5	2	1.5	1.5	4	3.5	3	2.5	2	—	—
4400	BHP	2.14	2.22	2.32	2.4	2.48	2.56	2.65	2.74	2.82	2.92	3	3.1	3.18	—	—	—
	Motor Type	A	A	A	A	A	A	A	A	A	C	E	E	E	—	—	—
	RPM	950	975	1005	1030	1055	1080	1110	1135	1155	1180	1200	1225	1245	—	—	—
Turns Open		4.5	4	3.5	3	3	2.5	2	1.5	1	4	3	3	2.5	—	—	—
4500	BHP	2.3	2.38	2.46	2.54	2.62	2.72	2.8	2.88	3	3.08	3.16	3.26	—	—	—	—
	Motor Type	A	A	A	A	A	A	A	A	D	E	E	E	—	—	—	—
	RPM	970	995	1020	1045	1070	1100	1125	1145	1170	1195	1215	1240	—	—	—	—
Turns Open		4.5	4	3.5	3	2.5	2	1.5	1.5	1	3.5	3	2.5	—	—	—	—

#### LEGEND

- — Operation Not Recommended
- BHP — Brake Horsepower
- ESP — External Static Pressure
- RPM — Revolutions Per Minute
- A — Units with Standard Static/Standard Motor Option
- B — Units with Low Static/Standard Motor Option
- C — Units with High Static/Standard Motor Option
- D — Units with Standard Static/Large 3 Hp Motor Option
- E — Units with High Static/Large 3 Hp Motor Option

#### NOTES:

1. Units factory shipped at ISO/AHRI setting with standard static sheave and drive at 2.5 turns open (4000 cfm at 0.5 in. wg ESP). Other speeds require field selection.

2. For applications requiring higher static pressures, contact your local representative.
3. Based on standard 12x12 blower.
4. Performance data does not include drive losses and is based on sea level conditions.
5. All airflow is rated at lowest voltage if unit is dual voltage rated, i.e., 208 v for 208-230 v units.
6. For wet coil performance first calculate the face velocity of the air coil (Face Velocity [fpm] = Airflow [cfm] / Face Area [sq ft]). Then for velocities of 200 fpm reduce the static capability by 0.03 in. wg, 300 fpm by 0.08 in. wg, 400 fpm by 0.12 in. wg and 500 fpm by 0.16 in. wg.

# Performance data (cont)



## 50HQP120 BLOWER DATA (CONT)

RATED CFM		EXTERNAL STATIC PRESSURE (in. wg)															
		0.0	0.1	0.2	0.3	0.4	0.5	0.6	0.7	0.8	0.9	1.0	1.1	1.2	1.3	1.4	1.5
4600	BHP	2.39	2.45	2.54	2.63	2.72	2.83	2.92	3	3.1	3.18	3.28	3.38	—	—	—	—
	Motor Type	A	A	A	A	A	A	A	D	D	E	E	E	—	—	—	—
	RPM	980	1000	1025	1050	1075	1105	1130	1150	1175	1195	1220	1245	—	—	—	—
4700	Turns Open	4	3.5	3.5	3	2.5	2	1.5	1	1	3.5	3	2.5	—	—	—	—
	BHP	2.46	2.52	2.62	2.72	2.82	2.92	3.02	3.12	3.22	3.32	3.4	3.5	—	—	—	—
	Motor Type	A	A	A	A	A	A	D	D	E	E	E	E	—	—	—	—
4800	RPM	985	1005	1030	1055	1080	1105	1130	1155	1180	1205	1225	1250	—	—	—	—
	Turns Open	4	3.5	3	2.5	2	1.5	1.5	1	4	3.5	2.5	2.5	—	—	—	—
	BHP	2.57	2.64	2.74	2.84	2.94	3.04	3.14	3.24	3.32	3.42	3.52	3.6	—	—	—	—
4900	Motor Type	A	A	A	A	A	D	D	D	E	E	E	E	—	—	—	—
	RPM	990	1010	1035	1060	1085	1110	1135	1160	1180	1205	1230	1250	—	—	—	—
	Turns Open	4	3.5	3	2.5	2	1.5	1	1	3.5	3	2.5	2	—	—	—	—
5000	BHP	2.68	2.78	2.88	3	3.06	3.16	3.26	3.36	3.44	3.54	3.64	3.75	—	—	—	—
	Motor Type	A	A	A	D	D	D	D	E	E	E	E	E	—	—	—	—
	RPM	995	1020	1045	1070	1090	1115	1140	1165	1185	1210	1235	1255	—	—	—	—
5000	Turns Open	3.5	3	3	2.5	1.5	1.5	1	4	3.5	3	2.5	2	—	—	—	—
	BHP	2.82	2.92	3	3.1	3.2	3.28	3.38	3.48	3.56	3.66	3.74	—	—	—	—	—
	Motor Type	A	A	D	D	D	D	D	E	E	E	E	E	—	—	—	—
5000	RPM	1005	1030	1050	1075	1100	1120	1145	1170	1190	1215	1235	—	—	—	—	—
	Turns Open	3.5	3	2.5	2	1.5	1	1	3.5	3	2.5	2	—	—	—	—	—

### LEGEND

- — Operation Not Recommended
- BHP** — Brake Horsepower
- ESP** — External Static Pressure
- RPM** — Revolutions Per Minute
- A** — Units with Standard Static/Standard Motor Option
- B** — Units with Low Static/Standard Motor Option
- C** — Units with High Static/Standard Motor Option
- D** — Units with Standard Static/Large 3 Hp Motor Option
- E** — Units with High Static/Large 3 Hp Motor Option

### NOTES:

1. Units factory shipped at ISO/AHRI setting with standard static sheave and drive at 2.5 turns open (4000 cfm at 0.5 in. wg ESP). Other speeds require field selection.

2. For applications requiring higher static pressures, contact your local representative.
3. Based on standard 12x12 blower.
4. Performance data does not include drive losses and is based on sea level conditions.
5. All airflow is rated at lowest voltage if unit is dual voltage rated, i.e., 208 v for 208-230 v units.
6. For wet coil performance first calculate the face velocity of the air coil (Face Velocity [fpm] = Airflow [cfm] / Face Area [sq ft]). Then for velocities of 200 fpm reduce the static capability by 0.03 in. wg, 300 fpm by 0.08 in. wg, 400 fpm by 0.12 in. wg and 500 fpm by 0.16 in. wg.

# Electrical data



## 50HQP072-120 (STANDARD UNITS)

UNIT 50HQP	VOLTAGE (3 Ph-60 Hz)	VOLTAGE RANGE		BLOWER MOTOR FACTORY- INSTALLED OPTION	COMPRESSOR			FAN MOTOR		TOTAL FLA	MCA	MOCP*
		Min	Max		Qty	RLA	LRA	HP	FLA			
072	208/230	187	253	Standard Large	2 2	10.4 10.4	73.0 73.0	1.5 2.0	4.0 6.2	24.8 27.0	27.4 29.6	35 35
	460	414	506	Standard Large	2 2	5.8 5.8	38.0 38.0	1.5 2.0	2.0 3.1	13.6 14.7	15.1 16.1	20 20
	575	518	633	Standard Large	2 2	3.8 3.8	36.5 36.5	1.5 2.0	1.4 2.3	9.0 9.9	9.9 10.8	15 15
096	208/230	187	253	Standard Large	2 2	13.7 13.7	83.1 83.1	2.0 3.0	6.2 9.2	33.6 36.6	37.0 40.0	50 50
	460	414	506	Standard Large	2 2	6.2 6.2	41.0 41.0	2.0 3.0	3.1 4.3	15.5 16.7	17.0 18.3	20 20
	575	518	633	Standard Large	2 2	4.8 4.8	33.0 33.0	2.0 3.0	2.3 3.4	11.9 13.0	13.1 14.2	15 15
120	208/230	187	253	Standard Large	2 2	15.6 15.6	110.0 110.0	2.0 3.0	9.2 14.1	40.4 45.3	44.3 49.2	50 60
	460	414	506	Standard Large	2 2	7.8 7.8	52.0 52.0	2.0 3.0	4.3 7.0	19.9 22.6	21.9 24.6	25 30
	575	518	633	Standard Large	2 2	5.8 5.8	38.9 38.9	2.0 3.0	3.4 5.2	15.0 16.8	16.5 18.3	20 20

## 50HQP072-120 (DUAL POINT UNITS)

UNIT 50HQP	VOLTAGE (3 Ph-60 Hz)	VOLTAGE RANGE		BLOWER MOTOR FACTORY- INSTALLED OPTION	COMPRESSOR						EMERGENCY POWER SUPPLY		
		Min	Max		Qty	RLA	LRA	TOTAL FLA	MCA	MOCP*	FAN MOTOR FLA	FAN MCA	FAN MOCP
072	208/230	187	253	Standard Large	2 2	10.4 10.4	73.0 73.0	20.8 20.8	23.4 23.4	30 30	4.0 6.2	5.0 7.8	15 15
	460	414	506	Standard Large	2 2	5.8 5.8	38.0 38.0	11.6 11.6	13.1 13.1	15 15	2.0 3.1	2.5 3.9	15 15
	575	518	633	Standard Large	2 2	3.8 3.8	36.5 36.5	7.6 7.6	8.6 8.6	15 15	1.4 2.3	1.8 2.9	15 15
096	208/230	187	253	Standard Large	2 2	13.7 13.7	83.1 83.1	27.4 27.4	30.8 30.8	40 40	6.2 9.2	7.8 11.5	15 20
	460	414	506	Standard Large	2 2	6.2 6.2	41.0 41.0	12.4 12.4	13.9 13.9	20 20	3.1 4.3	3.9 5.4	15 15
	575	518	633	Standard Large	2 2	4.8 4.8	33.0 33.0	9.6 9.6	10.8 10.8	15 15	2.3 3.4	2.9 4.3	15 15
120	208/230	187	253	Standard Large	2 2	15.6 15.6	110.0 110.0	31.2 31.2	35.1 35.1	50 50	9.2 14.1	11.5 17.6	20 30
	460	414	506	Standard Large	2 2	7.8 7.8	52.0 52.0	15.6 15.6	17.6 17.6	25 25	4.3 7.0	5.4 8.8	15 15
	575	518	633	Standard Large	2 2	5.8 5.8	38.9 38.9	11.6 11.6	13.1 13.1	15 15	3.4 6.2	4.3 6.5	15 15

### LEGEND

- FLA — Full Load Amps
- HACR — Heating, Air Conditioning, and Refrigeration
- LRA — Locked Rotor Amps
- MCA — Minimum Circuit Amps
- MOCP — Minimum Over Current Protection
- RLA — Rated Load Amps

\*Time-delay fuse or HACR circuit breaker.



# Typical piping and wiring

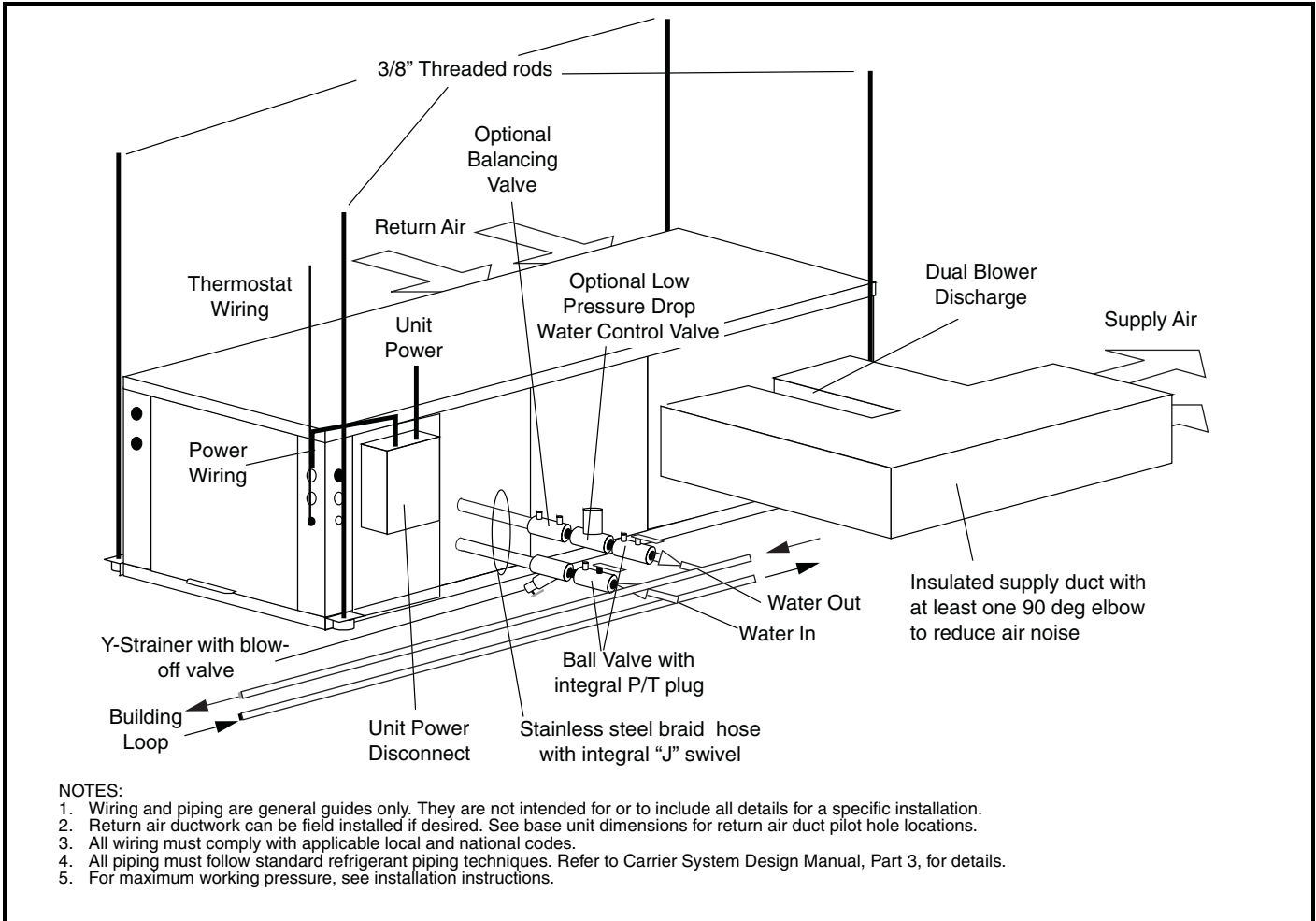

# Typical control wiring schematics



## 50HQP072-120 WITH COMPLETE C CONTROL (TYPICAL)

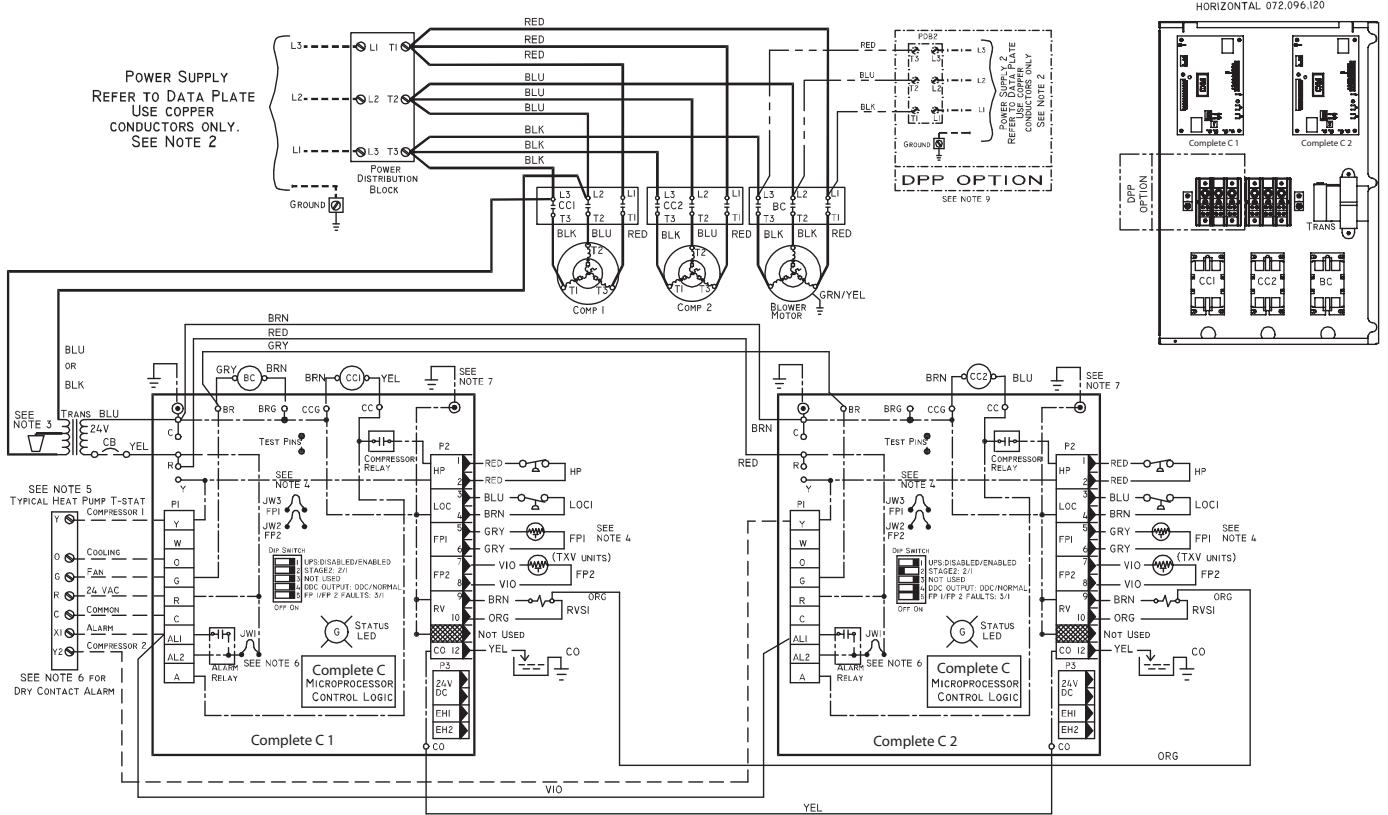

### LEGEND

<b>BC</b> — Blower Contactor	<b>---</b> Field Line Voltage Wiring	Ground
<b>CB</b> — Circuit Breaker	<b>- - -</b> Field Low Voltage Wiring	Solenoid Coil
<b>CC</b> — Compressor Contactor	<b>- · - · -</b> Printed Circuit Trace	Relay Contacts - N.O.
<b>CO</b> — Sensor, Condensate Overflow	<b>- · - · -</b> Optional Wiring	Relay Contacts - N.C.
<b>FP1</b> — Sensor, Water Coil Freeze Protection	Relay/Contactor Coil	Temperature Switch
<b>FP2</b> — Sensor, Air Coil Freeze Protection	Thermistor	Switch - Low Pressure
<b>HP</b> — High-Pressure Switch	Condensate Pan	Switch - High Pressure
<b>JW3</b> — Clippable Field Selection Jumper	Circuit Breaker	Wire Nut
<b>LOC</b> — Loss of Charge Pressure Switch		
<b>PDB</b> — Power Distribution Block		
<b>RVS</b> — Reversing Valve Solenoid		
<b>TRANS</b> — Transformer		
<b>TXV</b> — Thermostatic Expansion Valve		
<b>---</b> Factory Line Voltage Wiring		
<b>- - -</b> Factory Low Voltage Wiring		

### NOTES:

- Compressor and blower motor thermally protected internally.
- All wiring to the unit must comply with NEC (National Electrical Code) and local codes.
- 208/230-v transformers will be connected for 208-v operation. For 230-v operation, disconnect RED lead at L1, and attach ORG lead to L1. Close open end of RED lead.
- FPI thermistor provides freeze protection for WATER. When using ANTIFREEZE solutions, cut JW3 jumper.
- Typical heat pump thermostat wiring shown. Refer to thermostat installation instructions for wiring to the unit. Thermostat wiring must be "Class 1" and voltage rating equal to or greater than unit supply voltage.
- 24-v alarm signal shown. For dry alarm contact, cut JW1 jumper and dry contact will be available between AL1 and AL2.
- Transformer secondary ground via Complete C board standoffs and screws to control box. (Ground available from top two standoffs as shown.)
- Suffix 1 designates association with lead compressor. Suffix 2 with lag compressor.
- For dual point power (DPP) option, blower wire will connect to other PBD.

# Typical control wiring schematics (cont)



## 50HQ072-120 WITH DELUXE D CONTROL (TYPICAL)

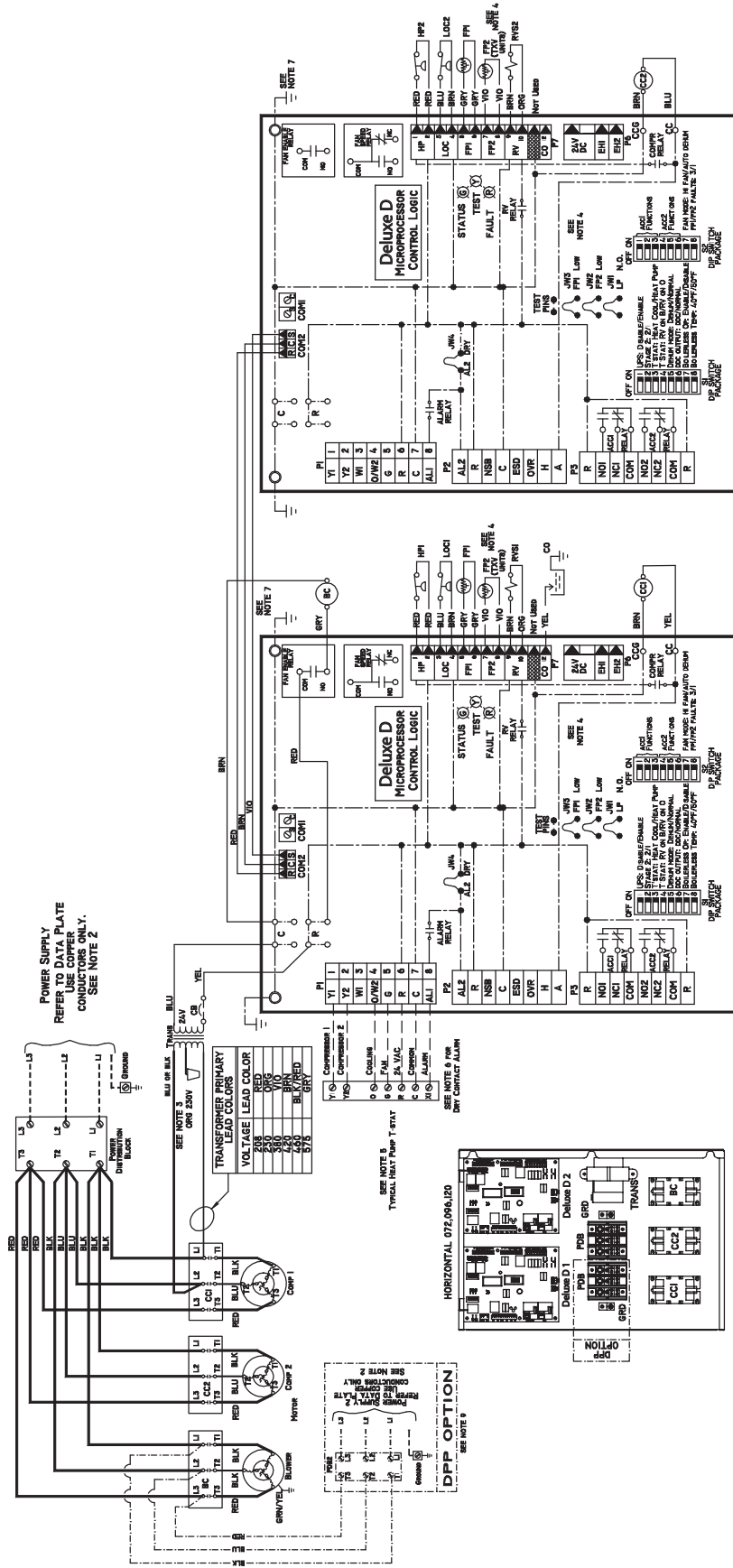

See legend and notes on page 23.

### PREMIERLINK™ CONTROLLER APPLICATIONS WITH COMPLETE C CONTROL

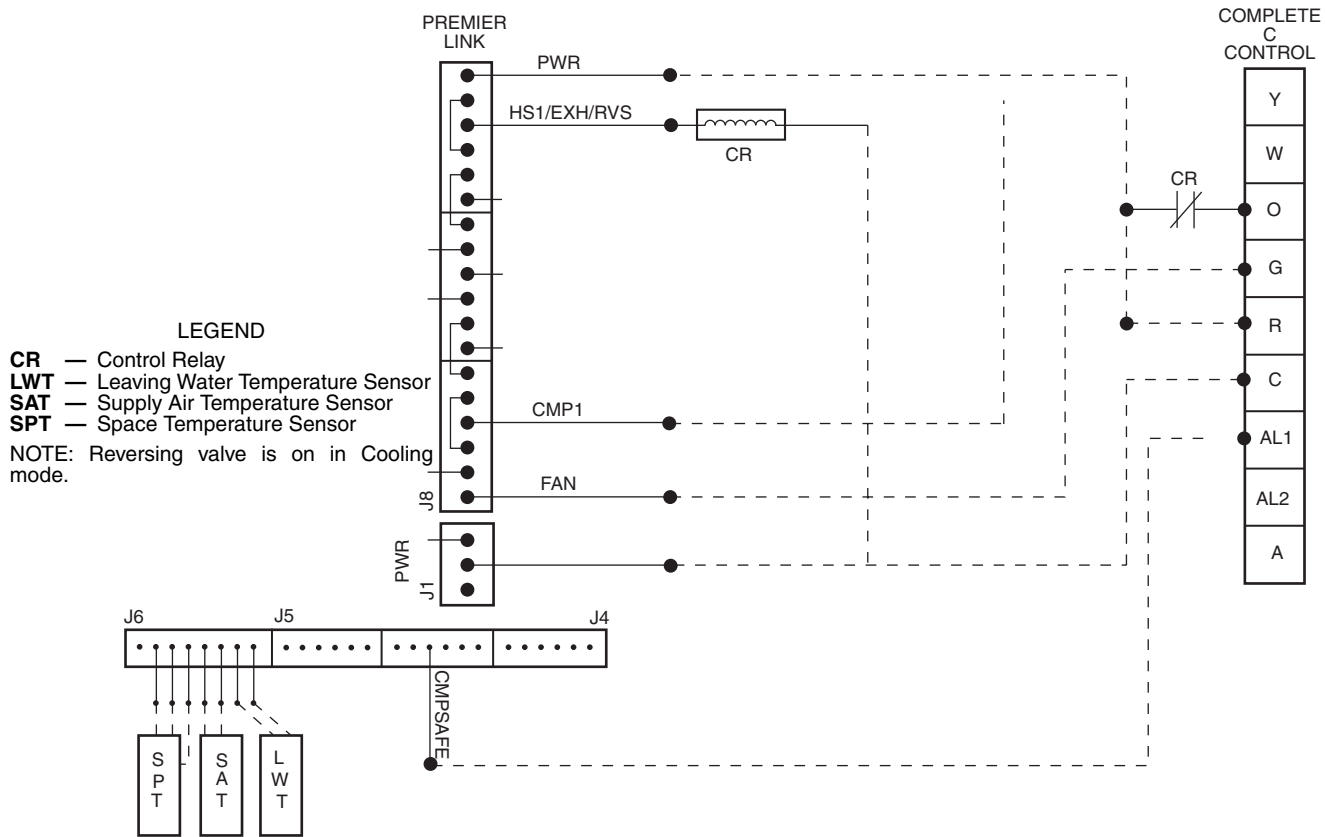

### PREMIERLINK CONTROLLER APPLICATIONS WITH DELUXE D CONTROL

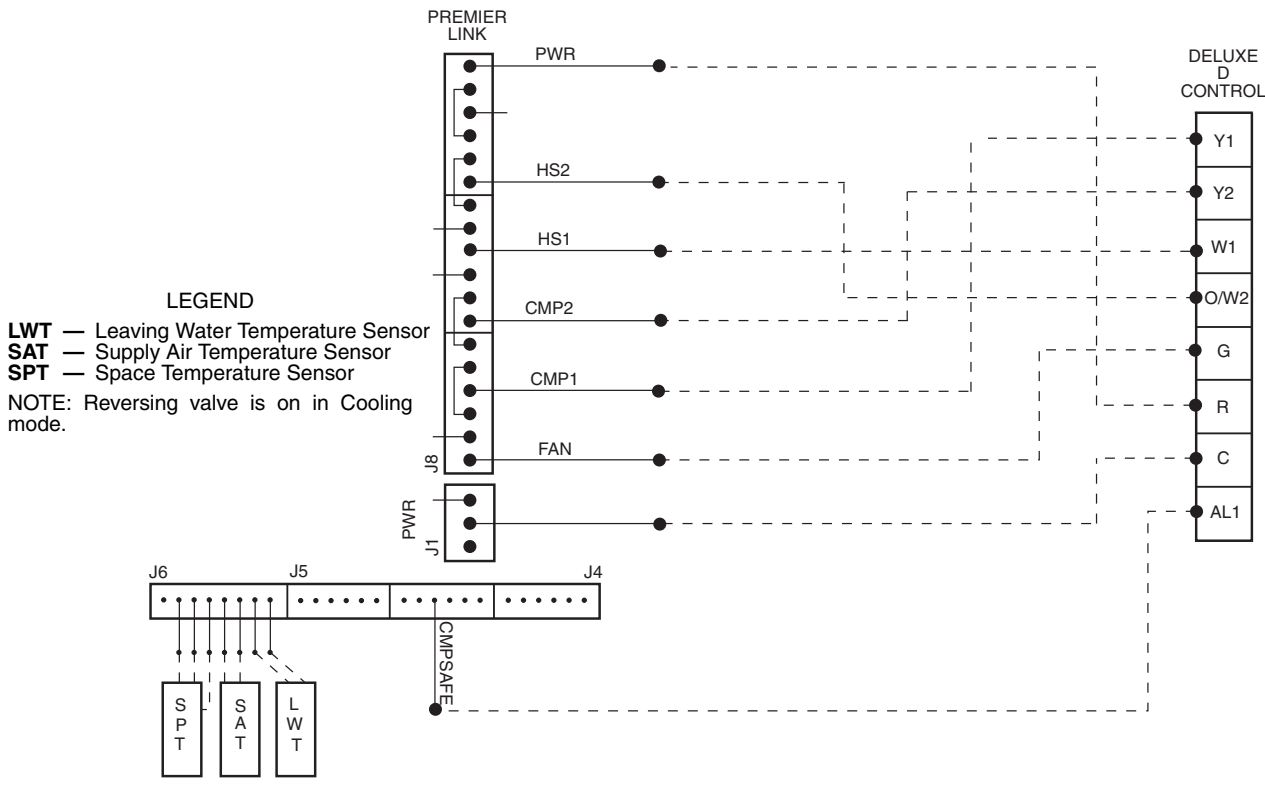

# Application data



Aquazone™ water source heat pump products are available in a flexible, efficient array of models, which can be used in all types of water loop, ground water, and ground loop type systems. Utilize Aquazone products to provide optimal energy efficient solutions and adapt to the most challenging design requirements.

## AQUAZONE PRODUCT GUIDE

50 SERIES	TYPE SIZE (tons)	APPLICATION
50HQP,VQP	Large Capacity 6-10 (HQP) 6 1/2-25 (VQP)	Environmentally sound unit with Puron® refrigerant (R-410A) designed to handle large zoned areas for all geothermal and boiler/tower applications.
50PC	Compact 1 1/4-5	Compact WSHP with Puron refrigerant (R-410A) for boiler/tower, ground water, or ground loop systems.
50PS	Premium Efficiency 1/2-6	Premium, ultra efficient unit with Puron refrigerant (R-410A) for new boiler/tower, ground water, or ground loop systems
50PEC	High Efficiency Console 3/4-1 1/2	Efficient console unit with Puron refrigerant (R-410A) and attractive design for finished interior, under-window installations.
50PT	Premium Efficiency 2-6	Premium, ultra efficient 2-stage unit with Puron refrigerant (R-410A) for new boiler/tower, ground water, or ground loop systems
50PSW	Water-to-Water 3-28	Efficient unit with Puron refrigerant (R-410A) serves as an alternative to pre-heat or cool air. Unit can be used as a stand-alone or supplemental boiler/chiller in most hydronic heating applications. Also conditions process fluids, lubricants, and refrigerants.
50RTG	Rooftop 3-20	Economical solution for indoor air quality (IAQ) problems and tempering ventilation air.
50VS	Premium Efficiency Vertical Stack Heat Pump 3/4 to 3 Tons	Ultra efficient unit with environmentally sound Puron refrigerant (R-410A) for boiler/tower and geothermal applications (condominiums, hotels, etc.). Stacked design allows for common piping and simplistic design.

## Water loop system

Water loop (or boiler/tower) system applications typically include a number of units plumbed to a common piping system. For optimal performance, this system should be designed between 2.25 and 3 gpm per ton of cooling capacity. The system is comprised of highly efficient packaged reverse cycle heat pump units interconnected by a water loop. The water circuit serves as both a sink and source for heat absorption and rejection and is designed for entering water temperatures between 60 F and 90 F. Within this temperature range units can heat or cool as required from the same water source. Transferring heat from warm to cold spaces in the building, whenever they coexist, conserves energy rather than creating new heat.

Refer to the **Carrier Water Source Heat Pump System Design Guide** for assistance with the design of water loop systems. The guide includes a practical approach for the latest and most current design recommendations including:

- Product application including horizontal, vertical, console, rooftop and water-to-water applications.
- Ventilation methods and system design including energy recovery.
- Acoustical considerations for different product types.
- Addressing indoor air quality (IAQ) issues such as condensate removal, humidity control.

- Air distribution design including diffuser selection/layout and ductwork design.
- Hydronic system design including pipe sizing/layout and boiler/tower sizing.
- Control configurations such as stand alone, DDC, DCV, and VVT® controls.
- WSHP Efficiency/Operational Cost Comparison chart.
- System variations such as a system without a boiler, variable pumping, and VAV for interior use.

## Ground water systems

To utilize Aquazone units in ground water applications, extended range should be specified. This will provide factory-installed insulation on the coaxial coil to prevent condensate from dripping when entering water temperatures are below 60 F. In addition, the copper coaxial coil installed on the Aquazone units may not be suitable for all water conditions. Refer to the Water Conditioning section for proper coaxial coil material selection.

**Surface water system** — This system is typically located near a lake or pond. In this application, the loop can be submerged in a series of coils beneath the water surface. The number of coils required depends on system load and design. This application requires minimum piping and excavation.

**Open loop system** — This system is used where ground water is plentiful. In this application, ground water is pumped through supply piping from the well to the building. The water is then pumped back into the ground through a discharge well as it leaves the building. An additional heat exchanger is usually installed between the building water piping system and the ground water piping system. This design limits the amount of piping and excavation required.

Aquazone units are provided with a standard TXV and are rated to extremely low temperatures to self-adjust the refrigeration circuit, therefore water regulating valves are not required on open loop systems. To conserve water on this type of system, a slow opening/closing solenoid valve is recommended.

## Ground loop systems

There are many commonly specified designs for ground loop applications. Typical designs include vertical loops and horizontal loops. In some applications, water is piped from the ground or lake directly to the water source heat pump. Piping is limited to the amount of pipe required to get the water from the source to the unit.

NOTE: When utilizing Aquazone water source heat pumps in ground loop systems, refer to design considerations in the ground water system section.

**Horizontal ground loop** — This system is used when adequate space is available and trenching can be easily accomplished. A series of parallel pipes are laid out in trenches 3 to 6 feet below the ground surface, and then back-filled. Often, multiple pipes are used to maximize the heat transfer capability of each trench. The amount of pipe and the size of the ground loop field are based on ground conditions, heating, and cooling requirements of the application and system design.

**Vertical ground loop** — This system is used in vertical borehole applications. This design is well suited for retrofit applications when space is limited or where landscaping is already complete and minimum disruption of the site is desired. The vertical ground loop system contains a single loop of pipe inserted into a hole. The hole is back-filled and grouted after the pipe is inserted. The completed loop is concealed below ground. The number of loops required depends on ground conditions, heating and cooling requirements, and the depth of each hole.

**Hybrid systems** — In some applications, it may be beneficial to incorporate a cooling tower into the ground loop system to reduce the overall cost. A hybrid system discards excess heat into the air and increases the cooling performance of the ground loop.

### Condensate drainage

**Venting** — Condensate lines should be properly vented to prevent fan pressure from causing water to hang up in the piping. Condensate lines should be pitched to assure full drainage of condensate under all load conditions. Chemical treatment should be provided to remove algae in the condensate pans and drains in geographical areas that are conducive to algae growth.

**Trapping** — Condensate trapping is an essential necessity on every water source heat pump unit. A trap is provided to prevent the backflow of moisture from the condensate pan and into the fan intake or downstream into the mechanical system. The water seal or the length of the trap depends on the positive or negative pressure on the drain pan. As a rule of thumb, the water seal should be sized for 1 in. for every 1 in. of negative pressure on the unit. The water seal is the distance from the bottom of the unit condensate piping connection to the bottom of the condensate drain line run-out piping. Therefore, the trap size should be double the water seal dimension.

Units should be sloped toward the drain at a 1/4 in. per foot pitch. If it is not possible to meet the pitch requirement, a condensate pump should be designed and installed at the unit to pump condensate to a building drain. Horizontal units are not internally trapped; therefore an external trap is necessary. Each unit must be installed with its own individual trap and means to flush or blowout the condensate drain. The design of a common trap or vent for multiple units is not acceptable. The condensate piping system should not be designed with a pipe size smaller than the drain connection pipe size.

### Water conditioning

In some applications, maintaining proper water quality may require the use of higher corrosion protection for the water-to-refrigerant heat exchanger. Water quality varies from location to location and is unique for each job. Water characteristics such as pH value, alkalinity, hardness, and specific conductance are of importance when considering any WSHP application. Water typically includes impurities and hardness that must be removed.

The required treatment will depend on the water quality as well as type of system. Water problems fall into three main categories:

1. Scale formation caused by hard water reduces the heat transfer rate and increases the water pressure drop through the heat exchanger. As water is heated, minerals and salts are precipitated from a solution and deposited on the inside surface of the pipe or tube.
2. Corrosion is caused by absorption of gases from the air coupled with water on exposed metal. Corrosion is also common in salt-water areas.
3. Organic growths such as algae can reduce the heat transfer rate by forming an insulating coating on the inside tube surface. Algae can also promote corrosion by pitting.

NOTE: In most commercial water loop applications, Aquazone™ WSHP units use copper water-to-refrigerant heat exchanger. Units can also be equipped with a cupronickel heat exchanger for applications where water is outside the standard contaminant limits for a copper heat exchanger.

### WATER QUALITY GUIDELINES

CONDITION	ACCEPTABLE LEVEL		
pH	7 to 9 range for copper. Cupronickel may be used in the 5 to 9 range.		
Total Hardness	Calcium and magnesium carbonate should not exceed 20 grains per gallon (350 ppm).		
Iron Oxides	Less than 1 ppm.		
Iron Bacteria	No level allowable.		
Corrosion*	Ammonia,	Max Allowable Level	Coaxial Metal
	Ammonium Hydroxide	0.5 ppm	Cu
	Ammonium Chloride,	0.5 ppm	Cu
	Ammonium Nitrate	0.5 ppm	Cu
	Ammonium Sulfate	0.5 ppm	CuNi
Chlorine/Chlorides	0.5 ppm	—	
Hydrogen Sulfide†	None Allowable		
Brackish	Use cupronickel heat exchanger when concentrations of calcium or sodium chloride are greater than 125 ppm are present. (Seawater is approximately 25,000 ppm.)		

\*If the concentration of these corrosives exceeds the maximum allowable level, then the potential for serious corrosion problems exists.

†Sulfides in the water quickly oxidize when exposed to air, requiring that no agitation occur as the sample is taken. Unless tested immediately at the site, the sample will require stabilization with a few drops of one Molar zinc acetate solution, allowing accurate sulfide determination up to 24 hours after sampling. A low pH and high alkalinity cause system problems, even when both values are within ranges shown. The term pH refers to the acidity, basicity, or neutrality of the water supply. Below 7.0, the water is considered to be acidic. Above 7.0, water is considered to be basic. Neutral water contains a pH of 7.0.

NOTE: To convert ppm to grains per gallon, divide by 17. Hardness in mg/l is equivalent to ppm.

### Acoustical design

Sound power levels represent the sound as it is produced by the source, the WSHP unit, with no regard to attenuation between the source and the space. Acoustical design goals are necessary to provide criteria for occupied spaces where people can be comfortable and communicate effectively over the background noise of the air-conditioning system and other background noise sources.

# Application data (cont)



Acoustical design goals are desirable sound pressure levels within a given conditioned space and are represented by noise criteria (NC) curves. Noise criteria curve levels represent a peak over a full spectrum of frequencies. A high value in a low frequency band has the same effect on NC level as a lower value in a high frequency band. It is important that sound levels be balanced over the entire spectrum relative to the NC curve. The lower the NC criteria curve, the more stringent the room acoustical design must be to meet the design goals.

It is important to know how to convert NC levels from the unit ratings in terms of sound power (Lw). This conversion depends on the specifics of the acoustical environment of the installation.

The resulting calculations are compared to the NC curve selected for the area to assess the acoustical design.

Some of the factors that affect conversion of sound power to sound pressure and consequent NC level include:

- Type of acoustical ceiling
- Use of metal or flex duct
- Absorption in the occupied space
- Location in the occupied space
- Open or closed layout plan
- Use of open or ducted returns
- Orientation of unit to occupant
- Use of lined or unlined duct

## OCTAVE BAND SOUND PRESSURE LEVEL (Lp) ASSOCIATED WITH NC CURVES

NOISE CRITERIA CURVES	OCTAVE BAND SOUND PRESSURE LEVEL (Lp)							
	Frequency (Hz)							
	63	125	250	500	1000	2000	4000	8000
NC-15	49	36	26	17	17	14	12	11
NC-20	52	41	33	27	22	19	17	16
NC-25	54	45	38	31	27	24	22	21
NC-30	58	49	41	36	31	29	28	27
NC-35	61	53	45	40	36	34	33	32
NC-40	64	57	50	45	41	39	38	37
NC-45	67	61	54	49	46	44	43	42
NC-50	71	64	58	54	51	49	48	47
NC-55	74	68	63	58	56	54	53	52
NC-60	77	71	67	63	61	59	58	57
NC-65	80	75	71	68	66	64	63	62

## WSHP sound control

The analysis of the projected sound level in the conditioned space caused by a WSHP unit located in a ceiling plenum is quite involved. The key is to have good sound power ratings (Lw) in dB on the equipment to determine the sound attenuation effect of the ductwork, ceiling and room. In combination with utilizing standard Aquazone™ equipment attenuating features or the advanced mute package features, suggestions for horizontal and vertical unit sound design are provided to design around the WSHP units.

Use the following guidelines for layout of Aquazone horizontal units to minimize noise:

1. Obtain sound power ratings in accordance with latest standards from manufacturers to select quietest equipment.
2. Do not locate units over a space with a required NC of 40 or less. Instead, locate units above less sensitive noise areas such as above or in equipment rooms, utility closets, restrooms, storage rooms, or above corridors.
3. Provide at least 10 feet between WSHP units to avoid the additive effect of two noise sources.
4. Provide an acoustical pad underneath the WSHP unit in applications where the unit must be mounted above noise sensitive areas such as private offices or conference rooms. The pad attenuates radiated noise. Be sure the pad has an area at least twice that of the WSHP footprint.
5. Maximize the installed height above the suspended ceiling.
6. Be sure the WSHP unit is located at least 6 feet away from any ceiling return grille to prevent line-of-sight casing noise to reach the space below.
7. Suspend the WSHP unit from the ceiling with hangers that utilize spring or neoprene type isolators to reduce vibration transmission.
8. Utilize flexible electrical connections to the WSHP unit. **DO NOT USE NOT RIGID CONNECTIONS.**
9. Utilize flexible loop water and condensate piping connections to the WSHP unit.
10. Use a canvas duct connector to connect the WSHP discharge to the downstream duct system. This reduces vibration-induced noise.
11. Provide acoustic interior lining for the first 20 feet of discharge duct, or until the first elbow is reached. The elbow prevents line-of-site sound transmission in the discharge duct.
12. Provide turning vanes in ductwork elbows and tees to reduce air turbulence.
13. Size the sheet metal supply duct with velocities no greater than 1000 fpm.
14. Ensure ductwork is rigid.
15. Use round duct whenever possible to further reduce noise.
16. Allow at least 3 equivalent duct diameters of straight duct upstream and downstream of the unit before allowing any fittings, transitions, etc.
17. Seal all penetrations around duct entering the space.
18. Provide a 4-ft runout duct made of flexible material to connect a diffuser to the supply trunk duct. The flex duct provides an "attenuating end-effect" and reduces duct-transmitted sound before it reaches the space. Typically a 6 dB sound reduction can be accomplished with the use of flex duct.
19. Locate the runout duct balancing damper as far away from the outlet diffuser as possible. Locating the balancing damper at the trunk duct exit is the best location.



- 20. If return air is drawn through a ceiling plenum, provide an acoustically lined return duct elbow or “L” shaped boot at the WSHP to eliminate line-of-sight noise into the ceiling cavity and possible through ceiling return air grilles. Face the elbow or boot away from the nearest adjacent WSHP unit to prevent additive noise.
- 21. Do not hang suspended ceiling from the ductwork.

**OPERATING LIMITS  
50HQP UNITS**

AIR LIMITS	COOLING (F)	HEATING (F)
Min. Ambient Air	45	45
Rated Ambient Air	80	70
Max. Ambient Air	100	85
Min. Ent. Air	50	40
Normal Entering Air db/wb	75/63-80/67	70
Max. Entering Air db/wb	110/83	80
<b>WATER LIMITS</b>		
Min. Entering Water	*30	45 (*20)
Normal Entering Water	40-90	40-90
Max. Entering Water	110	90

LEGEND

**db** — Dry Bulb  
**wb** — Wet Bulb

\*With antifreeze, optional extended range insulation and low temperature cutout jumper clipped for antifreeze.

**Solenoid valves**

In applications using variable flow pumping, solenoid valves can be field installed and operated from the control board in the Aquazone™ WSHP unit.

**Freeze protection**

Applications where systems are exposed to outdoor temperatures below freezing (32 F) must be protected from freezing. The most common method of protecting water systems from freezing is adding glycol concentrations into the water. Design care should be used when selecting both the type and concentrations of glycol utilized due to the following:

- Equipment and performance may suffer with high concentrations of glycol and other antifreeze solutions
- Loss of piping pressure may increase greatly, resulting in higher pumping costs
- Higher viscosity of the mixture may cause excess corrosion and wear on the entire system
- Acidity of the water may be greatly increased, promoting corrosion
- Glycol promotes galvanic corrosion in systems of dissimilar metals. The result is corrosion of one metal by the other, causing leaks.

# Guide specifications



## Commercial Horizontal Water Source Heat Pump Units

### HVAC Guide Specifications

Size Range: **70,000 to 120,000 Btuh Cooling Capacity**

Carrier Model Number: **50HQP**

#### Part 1 — General

##### 1.01 SYSTEM DESCRIPTION

- A. Heat pump units are designed to operate with 60 to 95 F water temperature or 20 to 110 F water temperature when the extended range option is selected. Units shall consist of high-efficiency scroll compressor(s) and shall have single or dual independent refrigeration circuits. The air discharge is horizontal with right/left discharge as specified on drawings.
- B. Units shall be individually packaged with wooden skid covered with protective corner posts and plastic stretch wrapping for maximum protection.

##### 1.02 QUALITY ASSURANCE

- A. Basic unit shall be rated and certified in accordance with AHRI/ISO/ASHRAE Standards.
- B. Units shall have insulation and adhesive which meet NFPA 90A requirements for flame spread and smoke generation, and assembled units shall be ETL certified.
- C. Units shall be factory tested under normal operating conditions at nominal water flow rates to assure proper operation of all components and safety devices.

#### Part 2 — Product

##### 2.01 EQUIPMENT

###### A. Heat Pump Assembly:

Factory-tested and assembled single-piece water source heat pump units shall be factory wired, charged with non-CFC R-410A refrigerant, contain refrigerant-to-water heat exchanger, refrigerant-to-air heat exchanger, 4-way reversing valve, fan motor assembly, compressor, metering device, and all internal controls and safety devices.

###### B. Unit Cabinet:

1. Unit shall be constructed of heavy gage galvanized sheet metal with removable service panels, hanging brackets, and insulated galvanized steel condensate pan of welded construction.
2. Supply and return water connections shall be copper FTP, flush-mounted and rigidly connected to prevent damage to tubing and/or noise generation.
3. Cabinet construction shall permit service testing without air bypass on coil and shall incorporate factory-installed supply ductwork connections. Direct connection to fan housing is not recommended due to sound considerations.
4. Unit shall have separate entrances for high and low-voltage electrical supplies.

5. One-in. wide filter bracket and 1-in. fiberglass disposable filter shall be provided on each unit.
6. All interior surfaces shall be lined with 1/2-in. thick, 1 1/2 lb per cu ft density acoustic type fiberglass insulation. All fiberglass shall be coated and all edges shall be tucked under flanges to prevent the introduction of glass fibers in the airstream.

###### C. Fan and Motor Assembly:

1. Units shall have belt-driven single or dual centrifugal fans. The fan motor shall be permanently lubricated with internal overload protection.
2. Fan motor shall be isolated from the fan housing by flexible isolation grommets.

###### D. Compressors:

Unit shall have heat pump duty, high-efficiency scroll compressor(s) with internal and external isolation.

###### E. Heat Exchangers:

1. Refrigerant-to-air coil shall be aluminum/copper finned-tube construction type rated for 450 psig and shall be fully degreased at the factory to prevent possible condensate blowoff.
2. Refrigerant-to-water heat exchanger shall be steel/copper tube-in-tube type rated for 450 psig refrigerant, 450 psig water-side pressures.
3. Optional steel/cupronickel refrigerant-to-water heat exchanger shall be used for open loop applications, or where water quality cannot be maintained as specified by manufacturer.

###### F. Refrigerant Components:

1. Refrigeration circuit components shall include liquid line service valve, suction line service valve, reversing valve, a full charge of compressor oil, and a holding charge of refrigerant.
2. Thermostatic expansion valve shall be provided for refrigerant metering.

###### G. Controls and Safeties:

1. Safety devices on all units shall include low-pressure sensor or loss-of-charge switch, high-pressure switch, low water temperature sensor, and condensate overflow switch.
2. The standard Complete C electronic control system shall interface with a heat pump (Y,O) wall thermostat (mechanical or electronic). The control system shall have the following features:
  - a. 75 va transformer.
  - b. Anti-short cycle time delay on compressor operation; time delay shall be 5 minutes minimum.
  - c. Random start on power-up.
  - d. Low voltage protection.
  - e. High voltage protection.
  - f. Condensate overflow shutdown.
  - g. Unit shutdown on low refrigerant pressures.



- h. Unit shutdown on high or low water temperature (selectable for antifreeze solutions).
  - i. Option to reset unit at thermostat or disconnect. Fault type shall be retained in memory if reset at thermostat.
  - j. Automatic intelligent reset. Unit shall automatically restart 5 minutes after shutdown if the fault has cleared. Should a fault occur 3 times sequentially, then lockout will occur.
  - k. Ability to defeat time delays for servicing.
  - l. Light-emitting diode (LED) to indicate high pressure, low pressure, improper voltage, water coil freeze protection, air coil freeze protection, condensate overflow, and control status.
  - m. Unit Performance Monitor to indicate inefficient operating conditions prior to unit lockout.
  - n. Remote fault type indication at thermostat.
  - o. Single harness connection for all safety devices.
  - p. Selectable 24-v or pilot duty dry contact alarm output.
  - q. 24-v output to cycle a motorized water valve with compressor contactor.
3. The optional Deluxe D electronic control shall have all the features of the Complete C control, with the following additional features:
- a. A removable thermostat connector.
  - b. Random start on return from night setback.
  - c. Minimized reversing valve operation for extended life and quiet operation.
  - d. Night setback control from low temperature thermostat, with 2-hour override initiated by a momentary signal from the thermostat.
  - e. Dry contact night setback output for digital night setback thermostats.
  - f. Ability to work with heat/cool (Y, W) thermostats.
  - g. Ability to work with heat pump thermostats using O or B reversing valve control.
  - h. Single grounded wire to initiate night setback or emergency shutdown.
  - i. Boilerless system control can switch automatically to electric heat at low loop water temperature.
  - j. Control board shall allow up to 3 units to be operated from one thermostat without any auxiliary controls.
  - k. A relay to operate an external damper. The control to be such that the damper will not open until 30 minutes after the unit comes back from Unoccupied mode.
  - l. Fan speed selection at thermostat.
  - m. A relay to restart a central pump or control a 24-v motorized water valve.
4. PremierLink™ Controller:  
This control will function with Carrier Comfort Network® (CCN) and ComfortVIEW™ software. It shall also be compatible with ComfortLink™ controllers. It shall be ASHRAE 62-99 compliant and Internet ready. It shall accept a CO<sub>2</sub> sensor in the conditioned space and be demand control ventilation (DCV) ready. The communication rate must be 38.4K or faster.
5. LONWORKS Interface System:  
Units shall have all features listed above (either Complete C or Deluxe D) and the control board shall be supplied with a LONWORKS interface board, which is LONMark certified. This will permit all units to be daisy chained via a 2-wire twisted pair shielded cable. The following points must be available at a central or remote computer location:
- a. space temperature
  - b. leaving-water temperature
  - c. discharge-air temperature
  - d. command of space temperature set point
  - e. cooling status
  - f. heating status
  - g. low temperature sensor alarm
  - h. low pressure sensor alarm
  - i. high pressure switch alarm
  - j. condensate sensor alarm
  - k. high/low voltage alarm
  - l. fan "ON/AUTO" position of space thermostat
  - m. unoccupied / occupied command
  - n. cooling command
  - o. heating command
  - p. fan "ON / AUTO" command
  - q. fault reset command
  - r. itemized fault code revealing reason for specific shutdown fault (any one of 7)
- This option also provides the upgraded 75 va control transformer with load side short circuit and overload protection via a built-in circuit breaker.
- H. Electrical:
- 1. A control box shall be located within the unit compressor compartment and shall contain a 75 va transformer, 24-volt activated, 3-pole compressor contactor, terminal block for thermostat wiring and solid-state controller for complete unit operation. Electro-mechanical operation WILL NOT be accepted.
  - 2. Units shall be nameplated for use with time-delay fuses or HACR circuit breakers.
  - 3. Unit controls shall be 24-volt and provide heating or cooling as required by the remote thermostat.

# Guide specifications (cont)



## I. Sound Attenuation Package (Mute Package):

Consists of attenuation material that is applied to the cabinet to reduce noise. Attenuating material shall be applied to the basepan, compressor access panels, and blower housing.

## J. High-Static Blower:

Provides increased airflow at various static pressure conditions.

## K. Special Features:

### 1. Aquazone™ Thermostat Controls:

- a. Programmable multi-stage thermostat offers 7-day clock, holiday scheduling, large backlit display and remote sensor capability.
- b. Programmable 7-day light-activated thermostat offers occupied comfort settings with lights on, and unoccupied energy savings with lights off.
- c. Programmable 7-day flush-mount thermostat offers locking coverplate with tamper-proof screws, flush to wall mount, dual point with adjustable deadband, O or B terminal, and optional remote sensor.
- d. Programmable 5-day thermostat offers 2-stage heat, 2-stage cool, auto changeover, 5-minute built-in compressor protection, and included locking cover.
- e. Non-programmable thermostat offers 2 heat stages, 2 cool stages, auto changeover, 5-minute built-in compressor protection, and included locking cover.

### 2. Aquazone™ system loop control panel shall include a pre-programmed, easy to use, Carrier Comfort Controller set up for a WSHP system. The features of the loop control panel shall be configured for the specific installation to include the following:

- a. The loop control panel shall coordinate, monitor, or control all WSHP units and ancillary equipment including cooling towers, boilers, and system pumps.
- b. Panel shall be provided with 2, 4, 6, or 8 stages of system heat rejection and addition.
- c. Panel shall be provided with stand-alone (i.e., non-communicating) operation with the ability to control 10 or 18 zones of WSHP units.
- d. Panel shall be provided to control variable frequency cooling tower fan operation.
- e. System pumping operation shall be configured for start/stop, lead/lag, or variable frequency pump operation.
- f. Loop panel shall be direct digital control compatible using the CCN and WSHP units using PremierLink CCN controllers.

## 3. Filter Rack (2 in.):

Filter rack enhances the filtration system of the water source heat pump.

NOTE: Filter rack does not include filters.

## 4. Fire-Rated Hose Kits:

Kits include a fixed MPT on one end and a swivel with an adapter on the other end. Hose kits can be either stainless steel or galvanized.

## 5. Ball Valves (Brass Body):

Valves are for shutoff and balancing water flow. Available with memory, memory stop, and pressure temperature ports.

## 6. Y Strainers (Bronze Body):

Strainers are “Y” type configuration with a brass cap. Maximum operating pressure rating of strainers is 450 psig. Strainer screen made of stainless steel.

## 7. Solenoid Valves (Brass Body):

Valves provide slow operation for quiet system application.

## 8. Hose Kit Assemblies:

Assemblies include a ported ball valve with pressure temperature (P/T) plug ports and flexible stainless steel hose with swivel and nipple. Return hose includes a ball valve, preset measure flow (gpm) with two P/T ports, and flexible stainless steel hose with a swivel and nipple.

## 9. Remote Sensors:

Sensors for thermostats are available wired or wireless.

## 10. Multiple-protocol WSHP Open controller remote sensors for Aquazone flush-mount thermostats and DDC control options. Only Carrier sensors can be used with the WSHP Open controller. Sensors are available as follows:

- a. SPT Standard offers space temperature sensor with communication port.
- b. SPT Plus offers space temperature sensor with set point adjust, local override with indicating light and communication port.
- c. SPT Pro offers space temperature sensor with LCD display, set point adjust, local override, alarm icon, outside air, and unit status with heating and cooling set points.
- d. SPT Pro+ offers space temperature sensor with LCD display, set point adjust, local override, alarm icon, outside air, unit status with heating and cooling set points, and fan speed control.

## 11. PremierLink™ Accessories:

Accessories include supply air temperature sensors, communicating room sensors, CO<sub>2</sub> sensors, and linkage thermostats to provide a fully integrated DDC (Direct Digital Controls) system.



12. Extended Range:

Extended range units provide an insulated water circuit for the coaxial coil and refrigerant circuit to prevent condensation, and therefore

potential dripping problems, in applications where the entering water temperature is beyond the normal operating range.





