

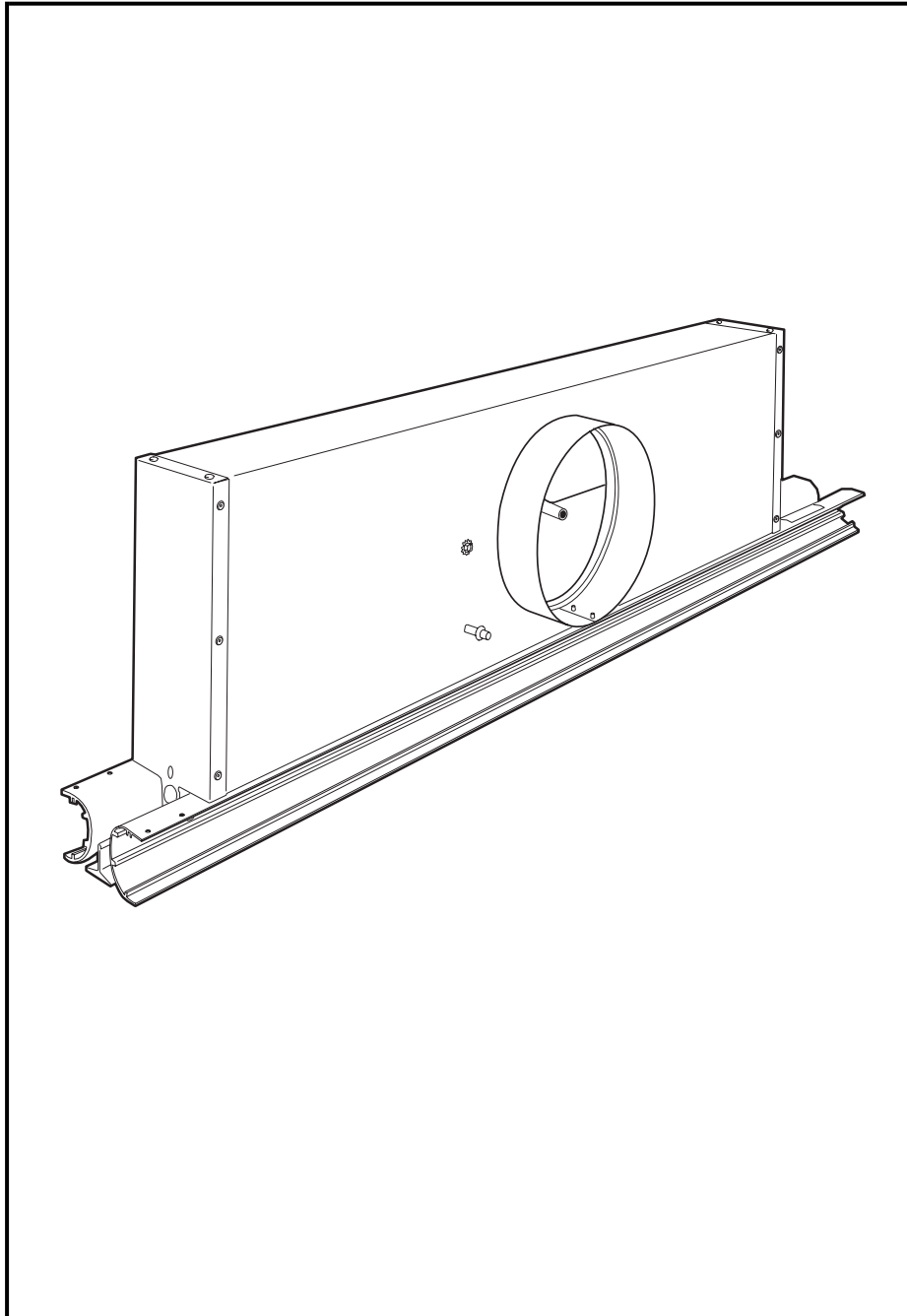

Product Data

35BD Boot Diffusers for Variable Volume Systems

0 to 500 Cfm Nominal Cooling
0 to 500 Cfm Nominal Cooling/Heating
0 to 120 Cfm Nominal Heating



Features/Benefits

Flexible, high-performance units

Model 35BD boot diffusers are available in 13 linear slot configurations for variable air volume cooling, heating, or combined cooling and heating service. The high induction ratio diffusers in the 35BD Series ensure an optimum mix of incoming air with room air, ensuring comfort for room occupants from wall-to-wall and ceiling-to-floor.

Cooling diffusers

The 35BD diffusers for cooling duty are available in 3 nominal airflow ranges: Up to 200 cfm (AG type), up to 400 cfm (CM type), and up to 500 cfm (CN type). One-way and 2-way air distribution patterns are available in nominal 2-ft, 4-ft, and 5-ft lengths.

Director series heating/cooling diffusers

These dual-purpose diffusers automatically change from cooling to heating mode and back. A self-contained heat-sensitive actuator changes the unit from 2-way cooling to 1-way heating when the supply-air temperature rises above 85 F. When the temperature falls below 68 F, the unit changes back to 2-way cooling.

The 35BD director diffusers are available in 3 nominal airflow ranges: Up to 200 cfm (DG type), up to 400 cfm (DM type), and up to 500 cfm (DN type). Two-slot versions provide 100% cooling and 50% heating airflow; 3-slot versions provide 100% cooling and 100% heating airflow. All DG, DM, and DN diffusers, both 2- and 3-slot versions, are



available in nominal 2-ft, 4-ft, and 5-ft lengths.

Table of contents

	Page
Features/Benefits	1,2
Model Number Nomenclature	2
Factory-Installed Options	3
Field-Installed Accessories	3
Physical Data	3
Dimensions	4-6
Selection Procedure — Cooling/Heating	7
Performance Data	8-15
Application Data — Cooling	16
Application Data — Heating	17
Guide Specifications	18

Heating diffusers

The 35BD diffuser for heating duty is available for nominal heating airflows up to 120 cfm (HS type). The diffuser has a down-blow slot arrangement and is available in nominal 2-ft and 4-ft lengths.

Rugged construction

Diffusers are formed from extruded aluminum for rigidity, light weight, and corrosion resistance. Boot casing is 24-gage galvanized steel with 1/2-in. dual-density fiberglass insulation (optional foil liner is available). Riveted boot end caps assure low leakage performance. All diffusers meet requirements of UL-181 (Underwriters' Laboratories) and NFPA-90A (National Fire Protection Association).

Superior performance

Exclusive aerodynamic designs ensure optimum mixing of distributed air with room air to prevent dumping, drafts, and dead spots.

Model number nomenclature

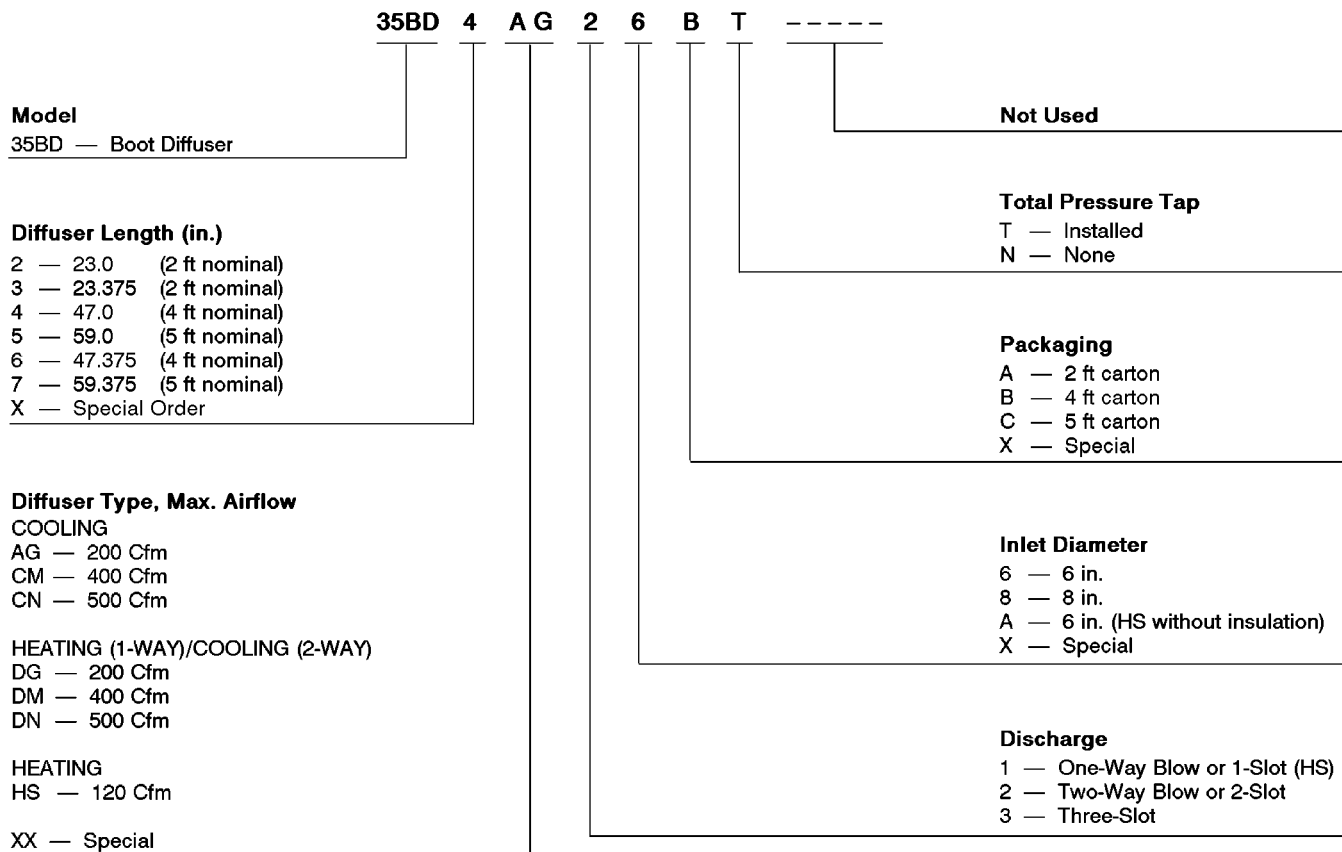

Factory-installed options



Pressure tap is available for unit balancing after installation.

Field-installed accessories

T-bar mounting bracket with clips supports boot diffusers, return air diffusers, and dummy diffusers. Brackets slide into each end of diffuser. Locking clips secure brackets to support. Accessory is available for both 3- and 4-in. wide diffusers.

Diffuser alignment plates straighten continuous runs of same-width diffusers in T-bar and other accessible ceiling applications. Keeps diffusers installed end-to-end aligned for a thin, straight appearance. Two fasteners (one on each side of diffuser) are required at each joint. Accessory is not applicable to heating (HS type) diffusers.

End trim strip finishes ends of diffusers that drop below grid or tile; makes neat joints and seams. Flange extends 3/4 in. beyond end of diffuser. Not applicable to heating (HS) or 3-slot diffusers.

Diffuser baffle closes off unused section of diffuser. Prevents air bypass and interrupts line of sight through diffuser. Can be cut to length as required for 3, 4, and 4 3/4-in. wide diffusers. Not applicable to heating (HS) or 3-slot diffusers.

15/16-in. filler trim piece simulates a T-bar grid member, where 47-in. diffusers are used, for a continuous, unbroken grid line. Fastens to alignment angles. Not applicable to heating (HS) diffuser.

Physical data

UNIT WEIGHTS (lb)

DIFFUSER TYPE	NOMINAL LENGTH (ft)		
	2	4	5
AG 1- and 2-Way	7.00	12.00	15.00
CM 1- and 2-Way	7.50	13.00	16.50
CN 1- and 2-Way	8.50	14.50	18.75
DG 2-Slot	7.25	12.50	15.75
DG 3-Slot	7.50	13.00	16.50
DM 2-Slot	7.75	13.50	17.25
DM 3-Slot	8.00	14.00	18.00
DN 2-Slot	8.75	15.00	18.50
DN 3-Slot	9.00	15.50	20.25
HS 1-Slot	7.50	11.00	*

*Not Available.

TYPES AG, DG, AND HS

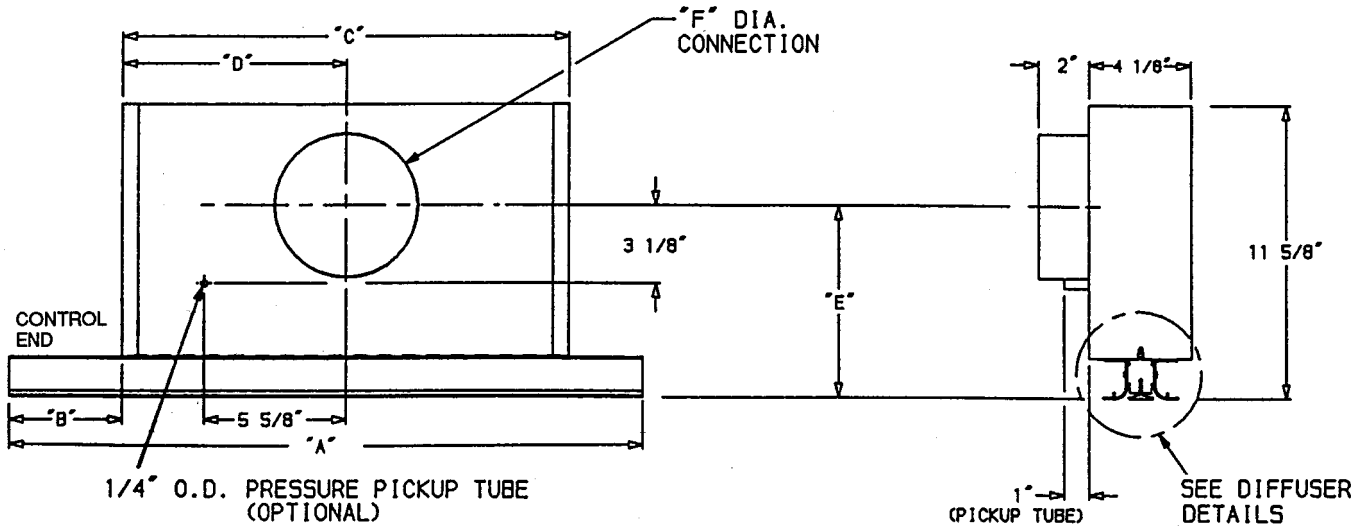

STANDARD EXTRUDED ALUMINUM TWO-WAY AG TYPE DIFFUSER FOR ALL LENGTHS

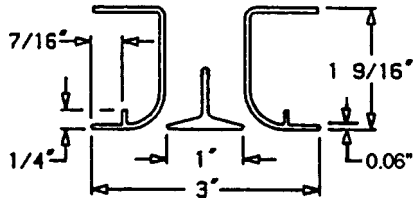

AG TYPE DIFFUSER (2-WAY)

STANDARD EXTRUDED ALUMINUM ONE-WAY AG TYPE DIFFUSER FOR ALL LENGTHS

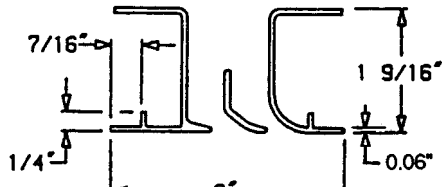

AG TYPE DIFFUSER (1-WAY)

STANDARD EXTRUDED ALUMINUM HS TYPE DIFFUSER FOR ALL LENGTHS

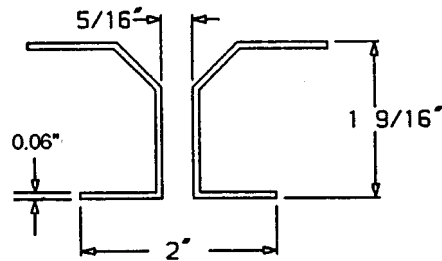

HS TYPE DIFFUSER (HEAT SLOT)

STANDARD EXTRUDED ALUMINUM DG 2-SLOT DIRECTOR DIFFUSER FOR ALL LENGTHS

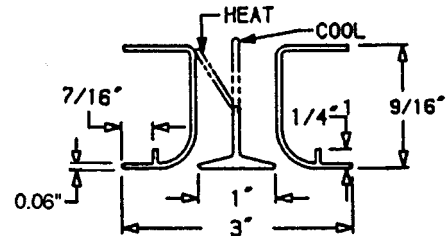

DG TYPE (2-SLOT) DIRECTOR DIFFUSER

STANDARD EXTRUDED ALUMINUM DG 3-SLOT DIRECTOR DIFFUSER FOR ALL LENGTHS

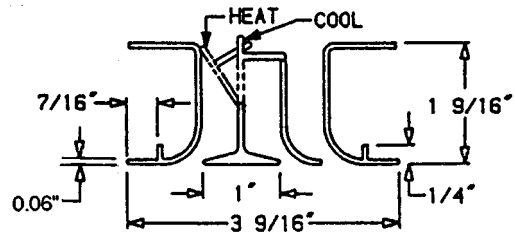

DG TYPE (3-SLOT) DIRECTOR DIFFUSER

TYPE	NOM SIZE (ft)	GRID WIDTH (in.)	DIMENSIONS (in.)						
			A	B	C	D	E	F	
AG DG	2	15/16	23	5 9/16	17 1/4	8 5/8	7 5/8	6	
		9/16	23 3/8	5 15/16			6 5/8	8	
		15/16	47	7 1/16	35 1/2	17 3/4	7 5/8	6	
		9/16	47 3/8	7 13/16			6 5/8	8	
	5	15/16	59	2 1/8	46 3/4	23 3/8	7 5/8	6	
		9/16	59 3/8	2 1/2			6 5/8	8	
		2	15/16	23	5 9/16	17 1/4	8 5/8	7 5/8	6
			9/16	23 3/8	5 15/16				
4	15/16	47	7 1/16	35 1/2	17 3/4	7 5/8	6		
	9/16	47 3/8	7 13/16						

TYPES CM, DM

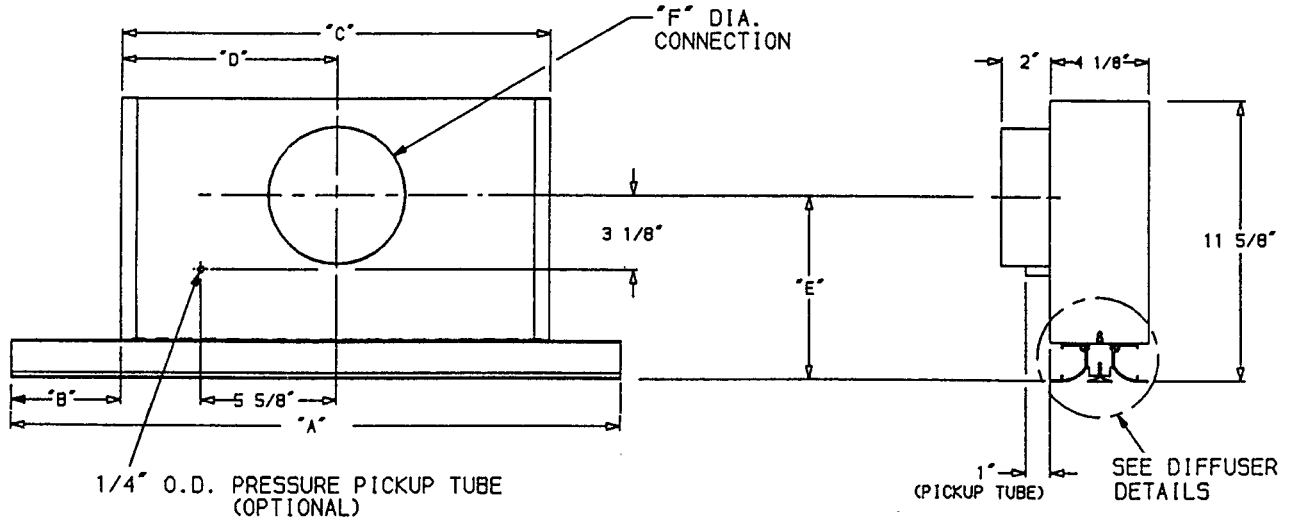

STANDARD EXTRUDED ALUMINUM TWO-WAY CM TYPE DIFFUSER FOR ALL LENGTHS

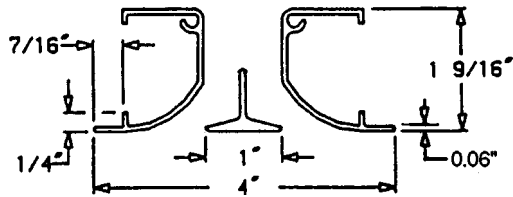

STANDARD EXTRUDED ALUMINUM DM 2-SLOT DIRECTOR DIFFUSER FOR ALL LENGTHS

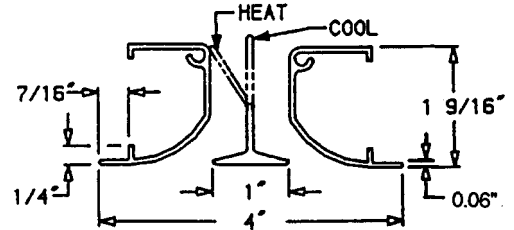

STANDARD EXTRUDED ALUMINUM ONE-WAY CM TYPE DIFFUSER FOR ALL LENGTHS

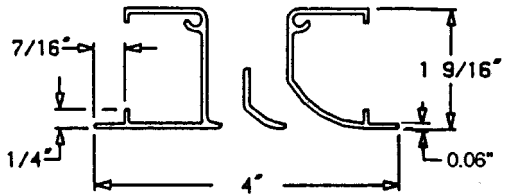

STANDARD EXTRUDED ALUMINUM DM 3-SLOT DIRECTOR DIFFUSER FOR ALL LENGTHS

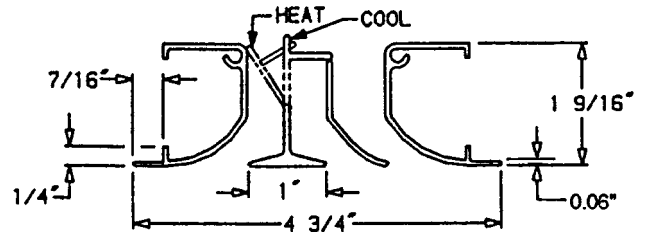

TYPE	NOM SIZE (ft)	GRID WIDTH (in.)	DIMENSIONS (in.)						
			A	B	C	D	E	F	
CM DM	2	15/16	23	59/16	17 1/4	8 5/8	7 5/8	6	
		9/16	23 3/8	5 15/16			6 5/8	8	
							7 5/8	6	
							6 5/8	8	
	4	15/16	47	7 7/16	35 1/2	17 3/4	7 5/8	6	
		9/16	47 3/8	7 13/16			6 5/8	8	
							7 5/8	6	
							6 5/8	8	
5	15/16	59	2 1/8	46 3/4	23 3/8	7 5/8	6		
	9/16	59 3/8	2 1/2			6 5/8	8		
						7 5/8	6		
						6 5/8	8		

Dimensions (cont)



TYPES CN, DN

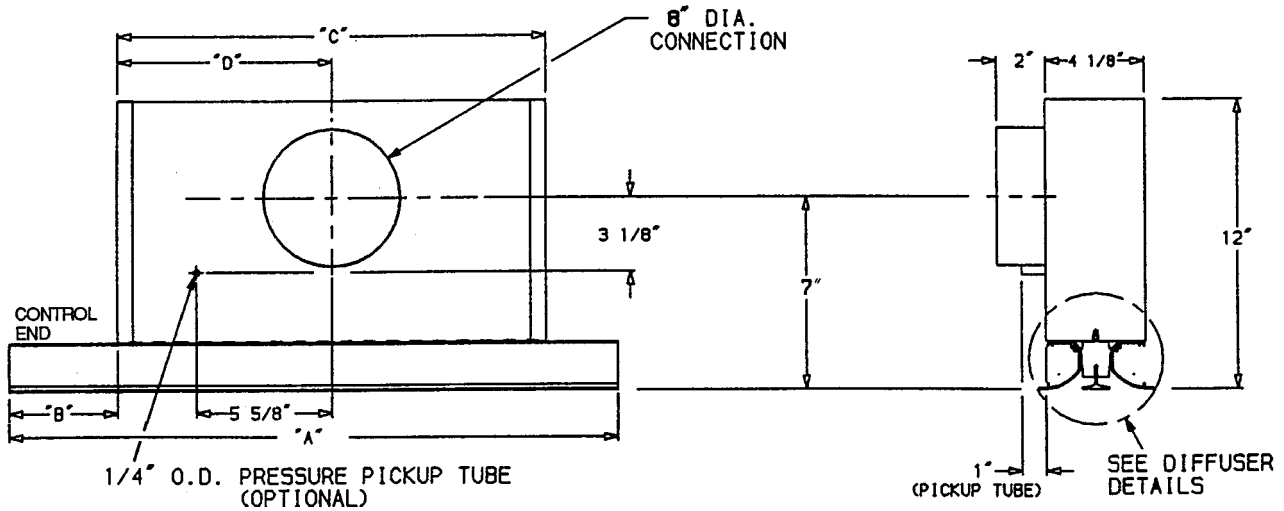

STANDARD EXTRUDED ALUMINUM TWO-WAY CN TYPE DIFFUSER FOR ALL LENGTHS

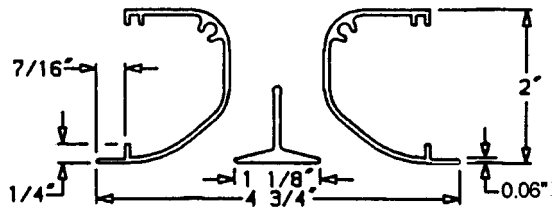

STANDARD EXTRUDED ALUMINUM DN 2-SLOT DIRECTOR DIFFUSER FOR ALL LENGTHS

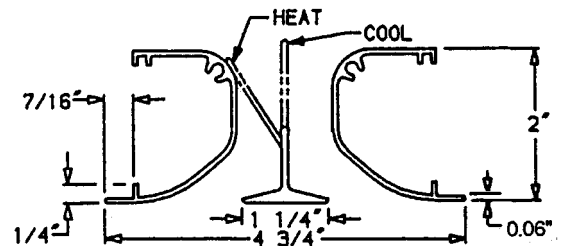

STANDARD EXTRUDED ALUMINUM ONE-WAY CN TYPE DIFFUSER FOR ALL LENGTHS

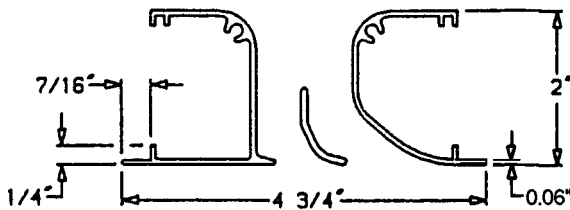

STANDARD EXTRUDED ALUMINUM DN 3-SLOT DIRECTOR DIFFUSER FOR ALL LENGTHS

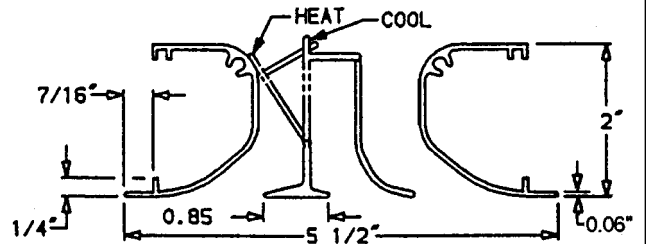

TYPE	NOM SIZE (ft)	GRID WIDTH (in.)	DIMENSIONS (in.)			
			A	B	C	D
CN DN	2	15/16	23	5 9/16	17 1/4	8 5/8
		9/16	23 3/8	5 15/16		
	4	15/16	47	7 1/16	35 1/2	17 3/4
		9/16	47 3/8	7 3/16		
	5	15/16	59	2 1/8	46 3/4	23 3/8
		9/16	59 3/8	2 1/2		

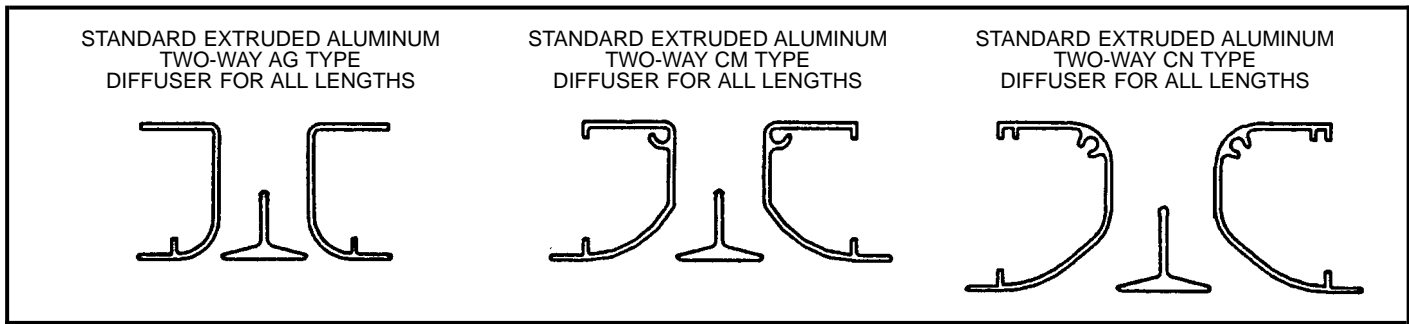

AIR THROW — 2-SLOT, 2-WAY DIFFUSERS

DIFFUSER TYPE	NOMINAL LENGTH (ft)								
	2			4			5		
	Airflow (Cfm)	Min (ft)	Max (ft)	Airflow (Cfm)	Min (ft)	Max (ft)	Airflow (Cfm)	Min (ft)	Max (ft)
AG	25	1	4	50	2	6	75	3	8
	50	3	8	100	4	12	100	4	11
	75	4	10	150	6	14	150	5	14
	100	6	12	200	8	16	200	7	16
	125	7	13	250	10	18	250	9	18
	150	8	14	300	12	20	300	11	20
	—	—	—	—	—	—	350	13	22
CM	50	2	6	100	3	9	150	5	14
	75	3	10	150	5	14	200	6	16
	100	4	13	200	6	16	250	8	18
	125	5	14	250	8	18	300	9	20
	150	6	15	300	9	20	350	11	22
	175	7	16	350	11	22	400	12	23
	200	8	17	400	12	23	450	14	24
—	—	—	—	—	—	500	15	25	
CN	75	2	7	150	3	10	125	2	7
	100	3	9	200	4	13	150	3	10
	125	4	10	250	5	16	200	4	14
	150	5	11	300	6	18	300	6	19
	175	6	12	350	7	21	400	8	23
	200	7	13	400	8	23	500	10	25
	225	8	14	450	9	24	600	12	27
250	9	16	500	10	25	700	14	29	

NOTES:

1. Data is suggested minimum and maximum coverage the unit can handle in a typical installation and still maintain desired room conditions.
2. Discharge velocity at minimum distance from diffuser is approximately 150 fpm. Velocity at maximum distance is approximately 50 fpm.
3. Distances are measured from centerline of the unit to the nearest obstruction (lighting fixture, opposing airstream, or interior wall).

For locations close to perimeter walls the following suggested guidelines can be used:

MAXIMUM DISTANCE from wall (L) should be equal to or less than the maximum throw (M) minus the ceiling height (H) divided by 2.

$$L \leq \frac{M - H}{2}$$

MINIMUM DISTANCE from wall equals the minimum throw divided by 2.

4. Data is based on area with 9-ft ceilings. For areas with higher ceilings, values may be reduced one ft per each ft of increase in ceiling height.
5. The above suggested guidelines may vary based on specific installation conditions.

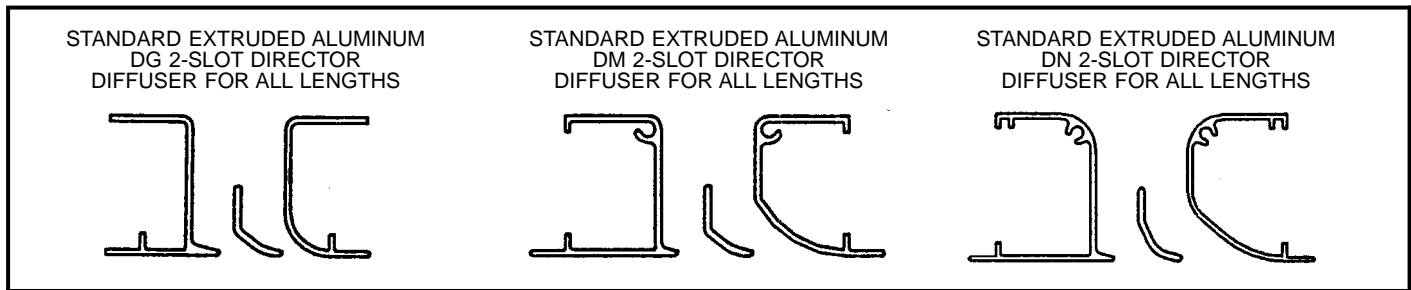

AIR THROW — 2-SLOT, 1-WAY DIFFUSERS

DIFFUSER TYPE	NOMINAL LENGTH (ft)								
	2			4			5		
	Airflow (Cfm)	Min (ft)	Max (ft)	Airflow (Cfm)	Min (ft)	Max (ft)	Airflow (Cfm)	Min (ft)	Max (ft)
AG	25	4	10	50	6	14	75	8	17
	50	8	14	100	10	19	100	11	19
	75	10	17	150	13	24	150	14	24
	100	11	19	200	16	28	200	16	28
	125	13	22	250	18	31	250	18	31
	150	14	24	300	20	34	300	20	34
	—	—	—	—	—	—	350	22	36
CM	50	7	14	100	9	19	150	14	23
	75	10	17	150	13	24	200	17	27
	100	12	20	200	18	28	250	18	31
	125	14	22	250	19	31	300	21	35
	150	16	24	300	20	34	350	23	39
	175	18	26	350	22	36	400	24	42
	200	20	28	400	22	38	450	25	45
—	—	—	—	—	—	500	26	49	
CN	75	8	13	150	11	24	125	8	16
	100	9	16	200	13	28	150	11	23
	125	10	18	250	16	32	200	15	30
	150	11	21	300	19	35	300	20	36
	175	12	24	350	22	38	400	24	41
	200	13	27	400	24	41	500	26	46
	225	15	30	450	25	43	600	27	51
	250	17	32	500	26	45	700	28	54

NOTES:

1. Data is suggested minimum and maximum coverage the unit can handle in a typical installation and still maintain desired room conditions.
2. Discharge velocity at minimum distance from diffuser is approximately 150 fpm. Velocity at maximum distance is approximately 50 fpm.
3. Distances are measured from centerline of the unit to the nearest obstruction (lighting fixture, opposing airstream, or interior wall).

For locations close to perimeter walls the following suggested guidelines can be used:

MAXIMUM DISTANCE from wall (L) should be equal to or less than the maximum throw (M) minus the ceiling height (H) divided by 2.

$$L \leq \frac{M - H}{2}$$

MINIMUM DISTANCE from wall equals the minimum throw divided by 2.

4. Data is based on area with 9-ft ceilings. For areas with higher ceilings, values may be reduced one ft per each ft of increase in ceiling height.
5. The above suggested guidelines may vary based on specific installation conditions.

Performance data (cont)

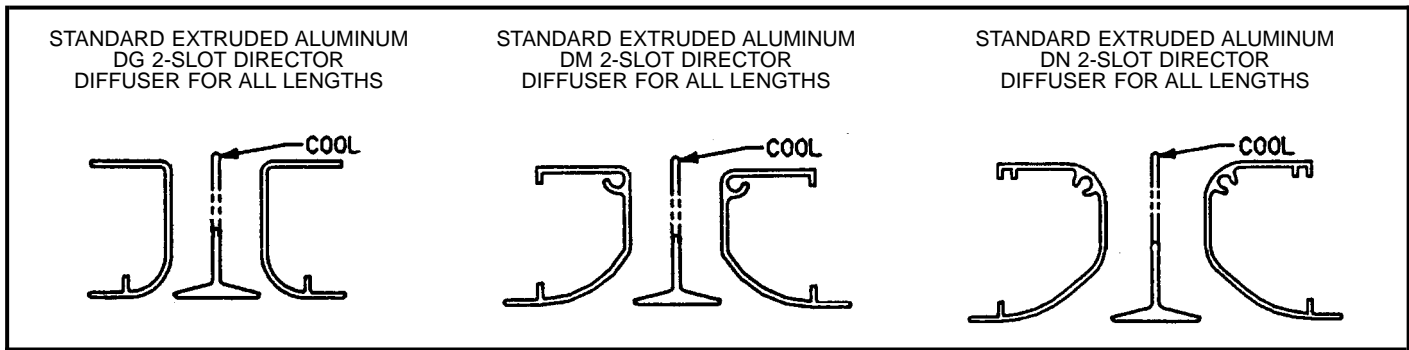

AIR THROW — 2-SLOT DIRECTOR DIFFUSERS — COOLING MODE (2-SLOT, 2-WAY)

DIFFUSER TYPE	NOMINAL LENGTH (ft)								
	2			4			5		
	Airflow (Cfm)	Min (ft)	Max (ft)	Airflow (Cfm)	Min (ft)	Max (ft)	Airflow (Cfm)	Min (ft)	Max (ft)
DG	25	1	4	50	2	6	75	3	8
	50	3	8	100	4	12	100	4	11
	75	4	10	150	6	14	150	5	14
	100	6	12	200	8	16	200	7	16
	125	7	13	250	10	18	250	9	18
	150	8	14	300	12	20	300	11	20
	—	—	—	—	—	—	350	13	22
DM	50	2	6	100	3	9	150	5	14
	75	3	10	150	5	14	200	6	16
	100	4	13	200	6	16	250	8	18
	125	5	14	250	8	18	300	9	20
	150	6	15	300	9	20	350	11	22
	175	7	16	350	11	22	400	12	23
	200	8	17	400	12	23	450	14	24
—	—	—	—	—	—	500	15	25	
DN	75	2	7	150	3	10	125	2	7
	100	3	9	200	4	13	150	3	10
	125	4	10	250	5	16	200	4	14
	150	5	11	300	6	18	300	6	19
	175	6	12	350	7	21	400	8	23
	200	7	13	400	8	23	500	10	25
	225	8	14	450	9	24	600	12	27
250	9	16	500	10	25	700	14	29	

NOTES:

1. Data is suggested minimum and maximum coverage the unit can handle in a typical installation and still maintain desired room conditions.
2. Discharge velocity at minimum distance from diffuser is approximately 150 fpm. Velocity at maximum distance is approximately 50 fpm.
3. Distances are measured from centerline of the unit to the nearest obstruction (lighting fixture, opposing airstream, or interior wall).

For locations close to perimeter walls the following suggested guidelines can be used:

MAXIMUM DISTANCE from wall (L) should be equal to or less than the maximum throw (M) minus the ceiling height (H) divided by 2.

$$L \leq \frac{M - H}{2}$$

MINIMUM DISTANCE from wall equals the minimum throw divided by 2.

4. Data is based on area with 9-ft ceilings. For areas with higher ceilings, values may be reduced one ft per each ft of increase in ceiling height.
5. The above suggested guidelines may vary based on specific installation conditions.

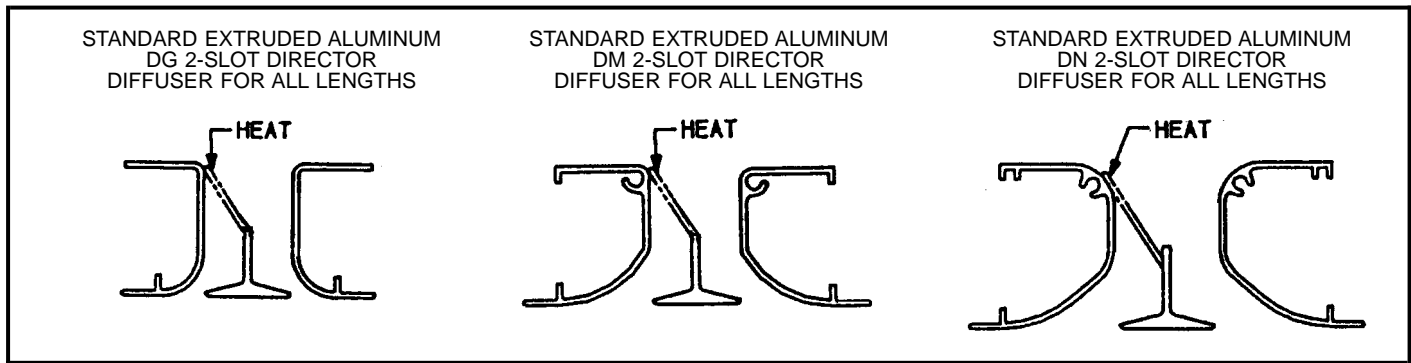

AIR THROW — 2-SLOT DIRECTOR DIFFUSERS — HEATING MODE (1-SLOT, 1-WAY)

DIFFUSER TYPE	NOMINAL LENGTH (ft)								
	2			4			5		
	Airflow (Cfm)	Min (ft)	Max (ft)	Airflow (Cfm)	Min (ft)	Max (ft)	Airflow (Cfm)	Min (ft)	Max (ft)
DG	—	—	—	25	4	10	—	—	—
	—	—	—	50	8	14	75	10	17
	—	—	—	75	10	17	100	11	19
	25	6	10	100	11	19	125	13	22
	50	8	14	125	13	22	150	14	24
	75	10	17	150	14	24	175	15	26
DM	—	—	—	50	6	14	75	8	17
	—	—	—	75	9	17	100	11	19
	—	—	—	100	11	19	125	13	22
	25	4	10	125	13	22	150	14	24
	50	6	14	150	14	24	175	15	26
	75	10	17	175	15	26	200	16	28
	100	11	19	200	16	28	225	17	29
DN	—	—	—	—	—	—	250	18	31
	—	—	—	75	10	17	—	—	—
	—	—	—	100	11	19	75	9	17
	—	—	—	125	12	22	100	11	19
	—	—	—	150	14	24	150	14	24
	50	7	14	175	15	26	200	16	28
	75	9	17	200	16	28	250	18	31
	100	11	19	225	17	30	300	20	34
125	13	21	250	18	31	350	21	36	

NOTES:

1. Data is suggested minimum and maximum coverage the unit can handle in a typical installation and still maintain desired room conditions.
2. Discharge velocity at minimum distance from diffuser is approximately 150 fpm. Velocity at maximum distance is approximately 50 fpm.
3. Distances are measured from centerline of the unit to the nearest obstruction (lighting fixture, opposing airstream, or interior wall).

For locations close to perimeter walls the following suggested guidelines can be used:

MAXIMUM DISTANCE from wall (L) should be equal to or less than the maximum throw (M) minus the ceiling height (H) divided by 2.

$$L \leq \frac{M - H}{2}$$

MINIMUM DISTANCE from wall equals the minimum throw divided by 2.

4. For optimum heating performance and comfort, diffusers should be placed a minimum of 2.5 ft from the perimeter wall with a supply air temperature between 90 F and 105 F.
5. Data is based on area with 9-ft ceilings. For areas with higher ceilings, values may be reduced one ft per each ft of increase in ceiling height.
6. The above suggested guidelines may vary based on specific installation conditions.

Performance data (cont)

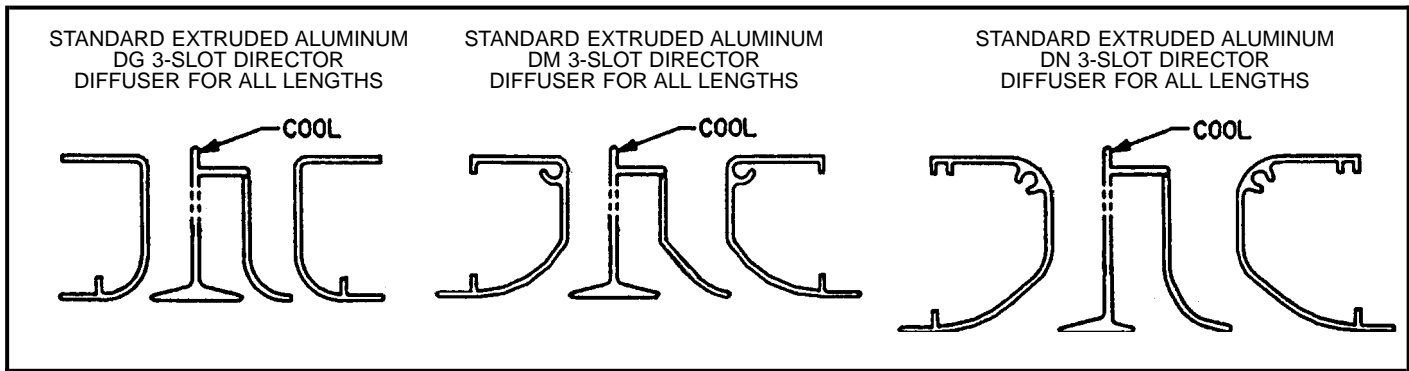

AIR THROW — 3-SLOT DIRECTOR DIFFUSERS — COOLING MODE (2-SLOT, 2-WAY)

DIFFUSER TYPE	NOMINAL LENGTH (ft)								
	2			4			5		
	Airflow (Cfm)	Min (ft)	Max (ft)	Airflow (Cfm)	Min (ft)	Max (ft)	Airflow (Cfm)	Min (ft)	Max (ft)
DG	25	1	4	50	2	6	75	3	8
	50	3	8	100	4	12	100	4	11
	75	4	10	150	6	14	150	5	14
	100	6	12	200	8	16	200	7	16
	125	7	13	250	10	18	250	9	18
	150	8	14	300	12	20	300	11	20
	—	—	—	—	—	—	350	13	22
DM	50	2	6	100	3	9	150	5	14
	75	3	10	150	5	14	200	6	16
	100	4	13	200	6	16	250	8	18
	125	5	14	250	8	18	300	9	20
	150	6	15	300	9	20	350	11	22
	175	7	16	350	11	22	400	12	23
	200	8	17	400	12	23	450	14	24
—	—	—	—	—	—	500	15	25	
DN	75	2	7	150	3	10	125	2	7
	100	3	9	200	4	13	150	3	10
	125	4	10	250	5	16	200	4	14
	150	5	11	300	6	18	300	6	19
	175	6	12	350	7	21	400	8	23
	200	7	13	400	8	23	500	10	25
	225	8	14	450	9	24	600	12	27
250	9	16	500	10	25	700	14	29	

NOTES:

1. Data is suggested minimum and maximum coverage the unit can handle in a typical installation and still maintain desired room conditions.
2. Discharge velocity at minimum distance from diffuser is approximately 150 fpm. Velocity at maximum distance is approximately 50 fpm.
3. Distances are measured from centerline of the unit to the nearest obstruction (lighting fixture, opposing airstream, or interior wall).

For locations close to perimeter walls the following suggested guidelines can be used:

MAXIMUM DISTANCE from wall (L) should be equal to or less than the maximum throw (M) minus the ceiling height (H) divided by 2.

$$L \leq \frac{M - H}{2}$$

MINIMUM DISTANCE from wall equals the minimum throw divided by 2.

4. Data is based on area with 9-ft ceilings. For areas with higher ceilings, values may be reduced one ft per each ft of increase in ceiling height.
5. The above suggested guidelines may vary based on specific installation conditions.

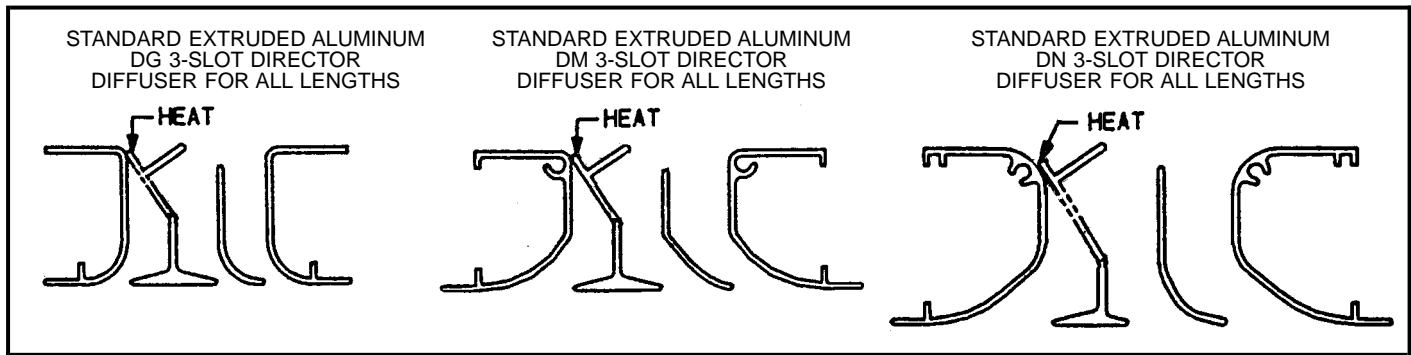

AIR THROW — 3-SLOT DIRECTOR DIFFUSERS — HEATING MODE (2-SLOT, 1-WAY)

DIFFUSER TYPE	NOMINAL LENGTH (ft)								
	2			4			5		
	Airflow (Cfm)	Min (ft)	Max (ft)	Airflow (Cfm)	Min (ft)	Max (ft)	Airflow (Cfm)	Min (ft)	Max (ft)
DG	25	2	7	50	3	11	75	3	10
	50	5	9	100	5	14	100	6	13
	75	8	13	150	8	17	150	8	15
	100	10	18	200	11	20	200	10	18
	125	12	22	250	13	23	250	12	21
	150	14	25	300	15	26	300	14	24
	—	—	—	—	—	—	350	15	27
DM	50	2	9	100	2	13	150	3	18
	75	3	14	150	5	19	200	5	24
	100	5	19	200	8	26	250	8	30
	125	7	22	250	11	31	300	11	34
	150	9	24	300	13	34	350	14	36
	175	11	26	350	15	36	400	17	39
	200	13	28	400	18	39	450	19	41
—	—	—	—	—	—	500	20	44	
DN	75	3	12	150	5	18	125	4	11
	100	5	14	200	9	26	150	6	15
	125	7	17	250	12	30	200	10	24
	150	9	20	300	15	33	300	14	28
	175	11	23	350	17	36	400	18	32
	200	12	27	400	19	39	500	21	36
	225	13	30	450	20	42	600	22	40
250	14	32	500	21	45	700	23	46	

NOTES:

1. Data is suggested minimum and maximum coverage the unit can handle in a typical installation and still maintain desired room conditions.
2. Discharge velocity at minimum distance from diffuser is approximately 150 fpm. Velocity at maximum distance is approximately 50 fpm.
3. Distances are measured from centerline of the unit to the nearest obstruction (lighting fixture, opposing airstream, or interior wall).

For locations close to perimeter walls the following suggested guidelines can be used:

MAXIMUM DISTANCE from wall (L) should be equal to or less than the maximum throw (M) minus the ceiling height (H) divided by 2.

$$L \leq \frac{M - H}{2}$$

MINIMUM DISTANCE from wall equals the minimum throw divided by 2.

4. For optimum heating performance and comfort, diffusers should be placed a minimum of 2.5 ft from the perimeter wall with a supply air temperature between 90 F and 105 F.
5. Data is based on area with 9-ft ceilings. For areas with higher ceilings, values may be reduced one ft per each ft of increase in ceiling height.
6. The above suggested guidelines may vary based on specific installation conditions.

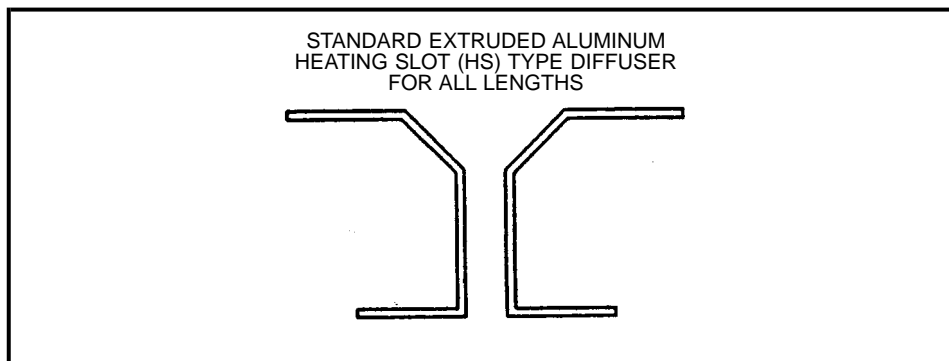

HS TYPE DIFFUSER PLACEMENT

DIFFUSER TYPE	NOMINAL LENGTH (ft)					
	Airflow (Cfm)	Placement (in.)		Airflow (Cfm)	Placement (in.)	
		Min	Max		Min	Max
HS	20-70	12	24	25-120	12	24

NOTES:

1. Minimum and maximum show distance diffuser should be located from perimeter wall in inches.
2. For optimum performance of the diffuser, the air temperature should be held between 90 and 115 F.

TYPICAL STATIC PRESSURE DROP (in. wg)

DIFFUSER TYPE, DISCHARGE, STYLE	INLET DIAMETER (in.)	DIFFUSER LENGTH (nom ft)					
		2		4		5	
		Airflow (Cfm)	Inlet Press. (in. wg)	Airflow (Cfm)	Inlet Press. (in. wg)	Airflow (Cfm)	Inlet Press. (in. wg)
AG 2-SLOT 2-Way and 1-Way Cooling DG 2-SLOT 2-Way Cooling DG 3-SLOT 2-Way Cooling, 1-Way Heating	6	25	0.02	50	0.02	75	0.02
		50	0.06	100	0.06	100	0.04
		75	0.15	150	0.15	150	0.09
		100	0.26	200	0.26	200	0.17
		125	0.42	250	0.42	250	0.26
		150	0.60	300	0.60	300	0.37
	8	—	—	—	—	350	0.51
		25	0.01	50	0.01	75	0.02
		50	0.06	100	0.06	100	0.04
		75	0.13	150	0.13	150	0.08
CM 2-SLOT 2-Way and 1-Way Cooling DM 2-SLOT 2-Way Cooling DM 3-SLOT 2-Way Cooling, 1-Way Heating	6	100	0.23	200	0.23	200	0.14
		125	0.35	250	0.35	250	0.22
		150	0.51	300	0.51	300	0.32
		—	—	—	—	350	0.44
		50	0.03	100	0.03	150	0.04
		75	0.07	150	0.07	200	0.08
	8	100	0.12	200	0.12	250	0.12
		125	0.20	250	0.20	300	0.17
		150	0.27	300	0.27	350	0.23
		175	0.36	350	0.36	400	0.30
DM 2-SLOT 2-Way Cooling	6	200	0.47	400	0.47	450	0.40
		—	—	—	—	500	0.49
		50	0.02	100	0.02	150	0.03
		75	0.05	150	0.05	200	0.05
	8	100	0.08	200	0.08	250	0.08
		125	0.13	250	0.13	300	0.12
		150	0.18	300	0.18	350	0.16
		175	0.25	350	0.25	400	0.21
DM 3-SLOT 2-Way Cooling, 1-Way Heating	8	200	0.33	400	0.33	450	0.27
		—	—	—	—	500	0.33



TYPICAL STATIC PRESSURE DROP (in. wg) (cont)

DIFFUSER TYPE, DISCHARGE, STYLE	INLET DIAMETER (in.)	DIFFUSER LENGTH (nom ft)					
		2		4		5	
		Airflow (Cfm)	Inlet Press. (in. wg)	Airflow (Cfm)	Inlet Press. (in. wg)	Airflow (Cfm)	Inlet Press. (in. wg)
CN 2-SLOT 2-Way and 1-Way Cooling DN 2-SLOT 2-Way Cooling DN 3-SLOT 2-Way Cooling, 1-Way Heating	8	75	0.03	150	0.03	125	0.01
		100	0.05	200	0.05	150	0.02
		125	0.07	250	0.07	200	0.03
		150	0.11	300	0.11	300	0.06
		175	0.14	350	0.14	400	0.11
		200	0.19	400	0.19	500	0.17
		225	0.24	450	0.24	600	0.26
250	0.29	500	0.29	700	0.34		
DG 2-SLOT 1-Way Heating	6, 8	25	0.05	50	0.05	50	0.03
		50	0.21	75	0.14	75	0.07
		75	0.50	100	0.21	100	0.12
		100	0.80	125	0.41	125	0.19
		—	—	—	—	150	0.28
DM 2-SLOT 1-Way Heating	6, 8	25	0.03	50	0.03	75	0.04
		50	0.12	75	0.07	100	0.07
		75	0.27	100	0.12	125	0.11
		100	0.47	125	0.19	150	0.16
		125	0.64	150	0.28	175	0.21
		—	—	175	0.37	200	0.27
DN 2-SLOT 1-Way Heating	8	25	0.01	50	0.01	100	0.03
		50	0.05	75	0.02	125	0.05
		75	0.10	100	0.04	150	0.07
		100	0.18	125	0.07	175	0.09
		125	0.28	150	0.10	200	0.12
		—	—	175	0.12	225	0.15
		—	—	200	0.18	250	0.19
HS 1-SLOT Downblow Heating	6	20	0.02	—	—	—	—
		30	0.04	50	0.03	—	—
		40	0.07	75	0.06	—	—
		50	0.11	100	0.11	—	—
		60	0.14	125	0.16	—	—
		70	0.20	—	—	—	—

LEGEND

— — Not applicable.

Maximum unit spacing

Interior zones use little air (0.4 to 0.6 cfm per sq ft) for cooling. Using the large capacity CM unit at 250 to 350 cfm each may cause units to be too widely separated. This causes poor coverage and poor air distribution. A good solution is to use a larger number of lower capacity AG units at 150 to 190 cfm each.

The maximum distance between units parallel to each other (blowing at each other) can and should be fairly great, 25 ft to 45 feet. (See Air Throw tables.) The maximum distance between the ends of units in the same row must be more limited for good coverage. The unit effectively covers a strip whose width is 3 to 4 times the unit's length. A 4-ft unit therefore covers an area whose width is 12 to 16 ft (maximum). The high induction ratio of the boot diffuser keeps the total room air motion at acceptable levels, even when the airflow per sq ft is low.

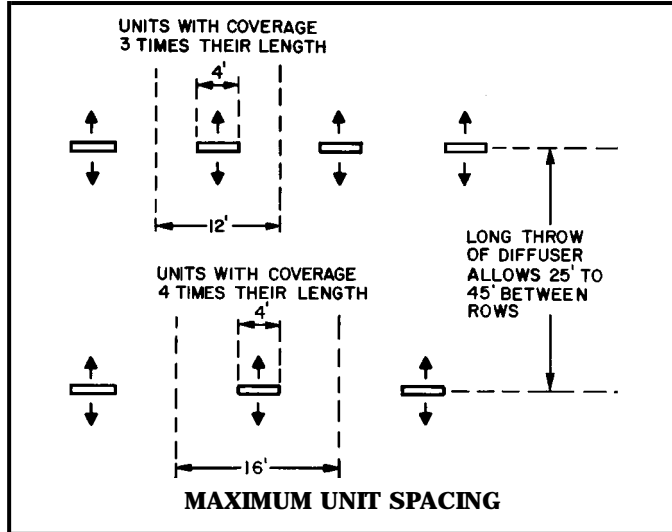

LAYOUTS

As shown, layouts should be made on a reflected ceiling plan (looking down from above the ceiling). Make the ceiling grid and lighting layouts first, then the diffuser layout. The center of the room is often an ideal location for a diffuser, but if the lighting occupies that location, the 35BD diffusers have enough flexibility to provide good air distribution when not centered.

For a 2-way blow diffuser, any location from the 1/4 point to the 1/4 point (wall to wall) is usually suitable. Outside of the 1/4 points, a one-way blow diffuser may be needed. Use a 2-way blow diffuser wherever possible and a one-way blow diffuser only when necessary.

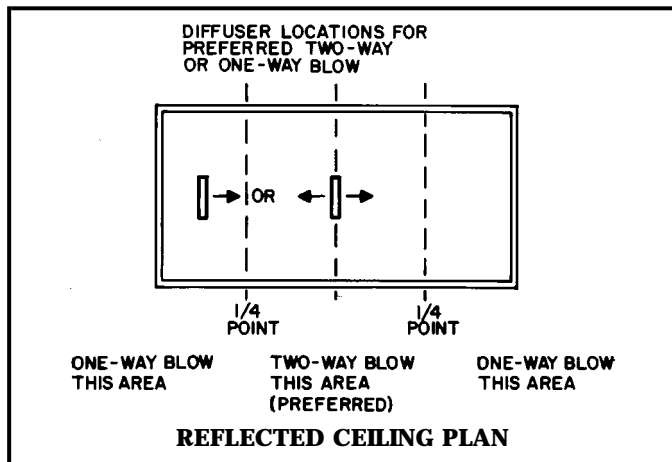

Minimum/maximum throw

Use the Air Throw tables to check the minimum and maximum throw. Check minimum throw for 2-way blow diffusers near walls and all one-way blow diffusers. In perimeter rooms, if 2-way blow units must be off center, locate them nearer the exterior wall, if possible.

If possible, put diffusers in line with one another, *not* blowing at each other. If units must blow at each other, then check the minimum throw values. *Do not put units closer together than 2 x distance minimum throw allows.* Downdrafts caused by placing the units too close together will bother room occupants.

Boot diffusers can be placed relatively close to a wall or partition, because the downdraft follows the wall and does not bother occupants. If furniture placed against the wall near a diffuser causes the air to be deflected, causing drafts, the problem can often be solved by moving the furniture 6 in. or so away from the wall.

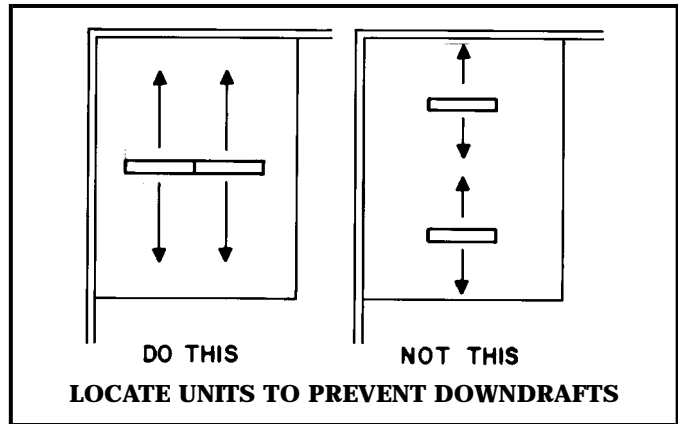

Staggered layout

A frequently used layout method is to stagger the units. This arrangement gives good coverage, solves the problem of drafts when units blow at each other, and is low cost. It also gives good flexibility for future partition changes.

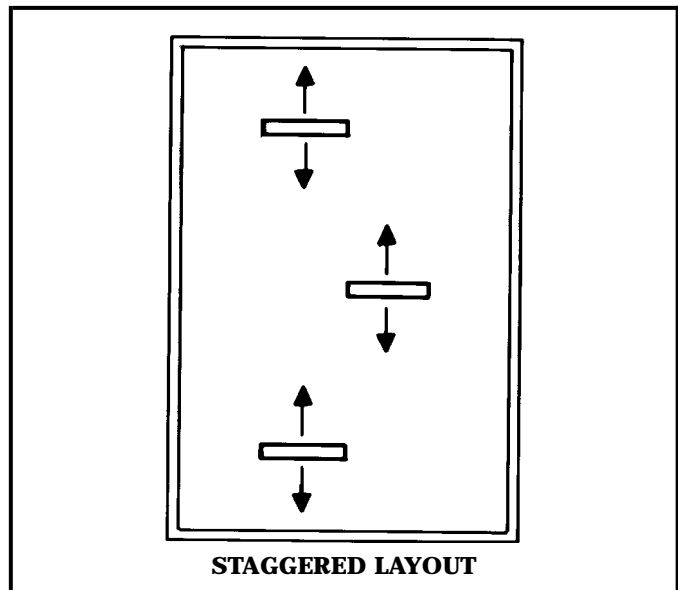

Application data — heating



Outlet type

Each outlet type has an optimum discharge velocity range and supply-air temperature range, which indicates best applications for the product.

DIFFUSER STYLE	OUTLET DISCHARGE	
	Velocity (fpm)	Temperature (F)
Downblow Slots	500 to 1250	90 to 115
One-Way Blow Slots	600 to 2200	80 to 105
Director Diffusers	800 to 2200	90 to 105

Design guidelines

Follow these design guidelines for good outlet selection:

- Establish outlet spacing (feet on-center), based on job requirements.
- Determine outlet airflow from on-center distances multiplied by room module load in cfm/linear foot.
- Select appropriate outlet from Air Throw tables.
- Adjust outlet supply-air temperature (and consequently outlet airflow) if a proper selection cannot be made with initial temperature choice. Keep temperature selections within guidelines noted above.

UNIT SLOT AREA (sq ft)

DIFFUSER TYPE	NOMINAL LENGTH (ft)		
	2	4	5
AG-1 1-Way Cooling	0.0462	0.0937	0.1261
AG-2, DG-2 2-Way Cooling	0.0462	0.0937	0.1261
CM-1 1-Way Cooling	0.0924	0.1849	0.2488
CM-2, DM-2 2-Way Cooling	0.0924	0.1849	0.2488
CN-1 1-Way Cooling	0.1386	0.2761	0.3715
CN-2, DN-2 2-Way Cooling	0.1386	0.2761	0.3715
DG-2 1-Slot Heating	0.0231	0.0468	0.0630
DG-3 2-Slot Heating	0.0462	0.0937	0.1261
DM-2 1-Slot Heating	0.0462	0.0924	0.1244
DM-3 2-Slot Heating	0.0924	0.1849	0.2488
DN-2 1-Slot Heating	0.0693	0.1380	0.1857
DN-3 2-Slot Heating	0.1307	0.2613	0.3516
HS-1 Downblow Slot	0.0385	0.0781	*

*Not available.

Outlet layout

Each style of outlet has an optimum location range for good performance. Follow these guidelines to assure good comfort for your project.

DIFFUSER STYLE	MINIMUM DISTANCE (ft)*	MAXIMUM DISTANCE (ft)*
Downblow Slots	1.0	2.0
One-Way Blow Slots	0.5	L (see below)
Director Diffuser	2.5	L (see below)

*Feet away from outside wall.

$$L = \frac{(M - H)}{2}$$

where H = ceiling height and M is maximum throw at equivalent airflows:

One-Way Blow Equivalent Cooling Airflow (Cfm) = Heating Airflow (Cfm)

2-Slot Director Equivalent Cooling Airflow (Cfm) = 2 x Heating Airflow (Cfm)

3-Slot Director Equivalent Cooling Airflow (Cfm) = Heating Airflow (Cfm)

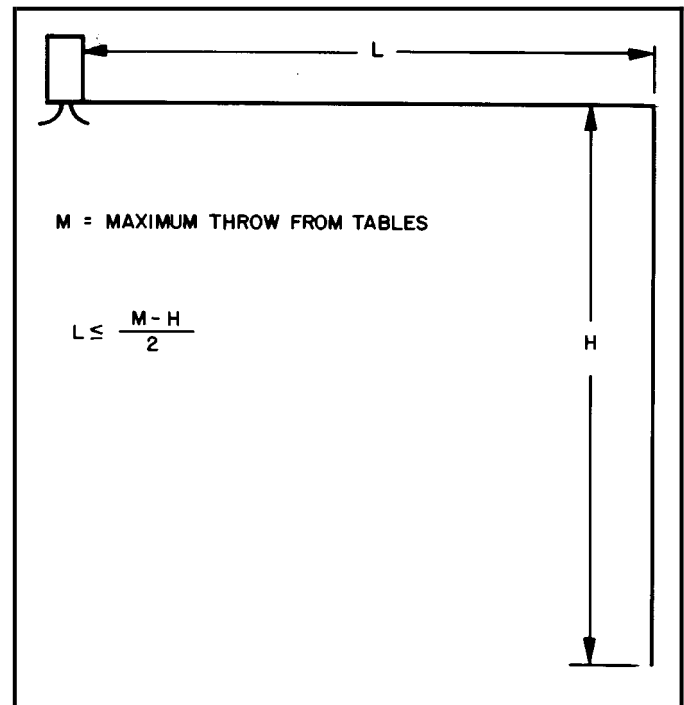

Boot Diffuser for Variable Volume Systems HVAC Guide Specifications

Size Range: **0 to 500 Cfm, Nominal (Cooling)**
0 to 500 Cfm, Nominal (Cooling/Heating)
0 to 120 Cfm, Nominal (Heating)

Carrier Model Number: **35BD**

Part 1 — General

1.01 SYSTEM DESCRIPTION

Boot diffuser for installation in a ceiling. Manufacturer shall supply unit(s) of the design, number, size, and performance as shown on equipment drawings and schedules. Unit(s) are for use in conjunction with air terminals, air distribution manifolds, and distribution ductwork.

1.02 QUALITY ASSURANCE

Insulation shall meet NFPA-90A requirements for flame spread and smoke generation and UL-181 requirements for anti-erosion, anti-corrosion, and anti-fungus properties.

1.03 DELIVERY AND STORAGE

Units shall be stored and handled per manufacturer's recommendations.

Part 2 — Products

2.01 EQUIPMENT

A. General:

Factory-assembled boot diffuser for variable volume systems. Unit shall include a diffuser and boot combination designed for cooling, heating, or cooling/heating applications. Unit shall have an optional pressure tap to facilitate balancing. Unit shall be clearly marked with an identification label that lists such information as nominal airflow, diffuser length, connection diameter, and discharge, where applicable.

B. Boot Construction:

Unit boot shall be constructed of 24-gage galvanized steel with 1/2-in. dual-density fiberglass insulation and riveted end caps to ensure low-leakage performance. An optional foil-faced liner shall be available.

C. Diffuser Construction:

Unit diffuser shall be aluminum with baked recoatable enamel finish. Diffuser style and method of support shall be coordinated with the ceiling construction for proper performance and appearance.

D. Cooling Diffusers:

Cooling diffusers shall be available in 3 nominal air-flow ranges (AG type-200 cfm, CM type-400 cfm; CN type-500 cfm) and 2 types of air distribution patterns (1-way and 2-way) in nominal lengths of 2 ft, 4 ft, and 5 feet.

E. Heating/Cooling Diffusers:

Heating/cooling diffusers shall be available in 3 nominal cfm ranges (DG type-200 cfm; DM-type 400 cfm; DN type-500 cfm) for 2-way distribution cooling and 1-way distribution heating. Diffusers shall be capable of automatic changeover from heating to cooling with no manual adjustment required. Changeover shall occur between 68 F and 85 F supply-air temperature. Diffusers shall be available in 2-ft, 4-ft, and 5-ft lengths.

F. Heating Diffuser:

Heating diffuser shall be available in a downblow slot arrangement capable of delivering 25 to 120 cfm for optimum heating performance. Diffusers shall be available in 2-ft and 4-ft lengths.

